

G3:ID – Innovation Discipline Approach



The Innovation Challenge

- Building Growth from the Revenue Sources through Innovation

Base Retention



Routine and incremental product enhancements that maintain the current customer base

Share Gain



Fundamental and breakthrough product improvements that drive share penetration

Market Positioning



New-to-market product innovations that create new segments of fast-growing demand

Adjacent Markets



Apply technology capabilities to create advantage in different markets



The Innovation Challenge

- BUT...
 - Innovation is cumbersome
 - Innovation is messy
 - Innovation is risky
 - And Innovation Killers are lurking everywhere



The Innovation Challenge

Innovation is cumbersome

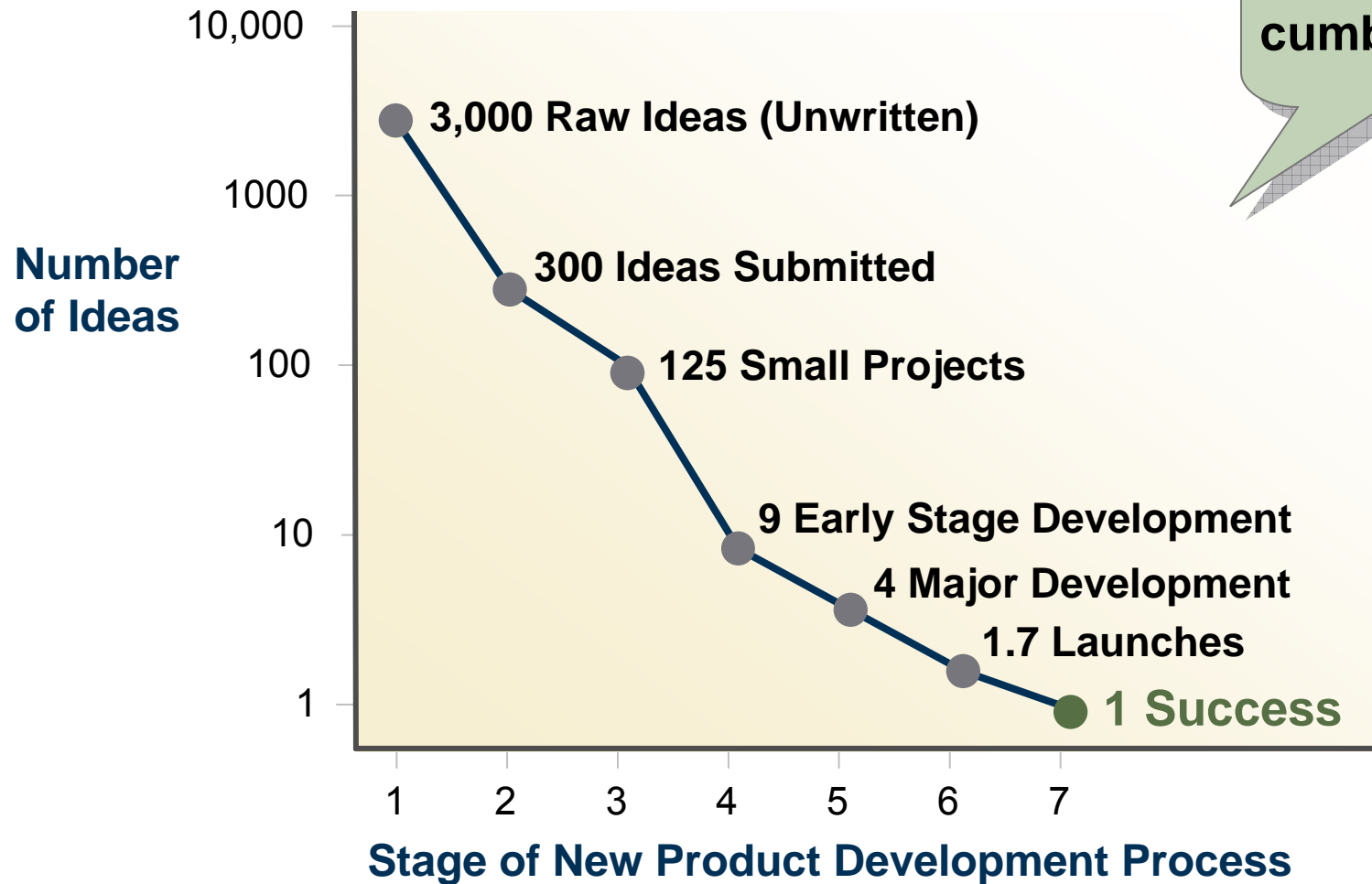

Source: G. Stevens and J. Burley, "3,000 Raw Ideas = 1 Commercial Success!" *Research Technology Management*, 40(3): 16-27, May-June, 1997.



Traditional Science of Innovation

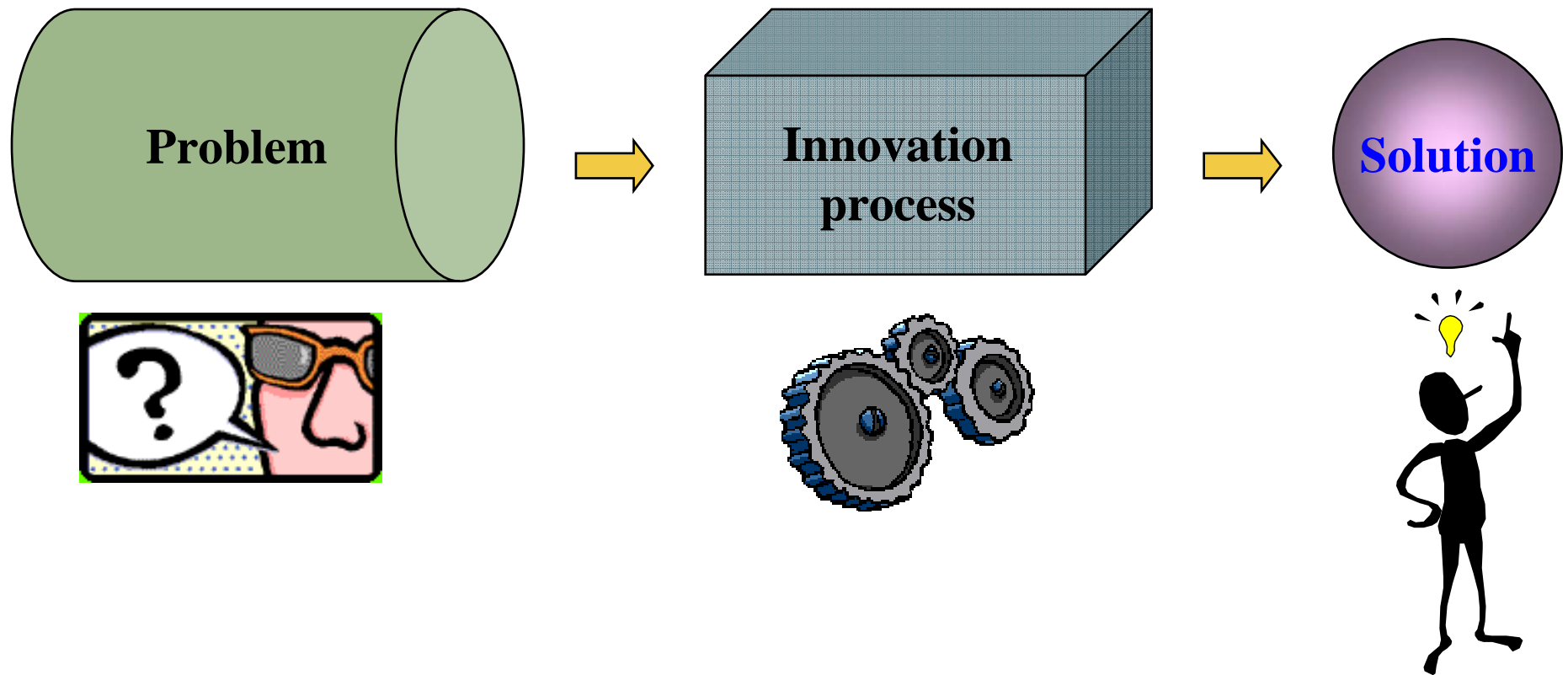



Traditional Science of Innovation

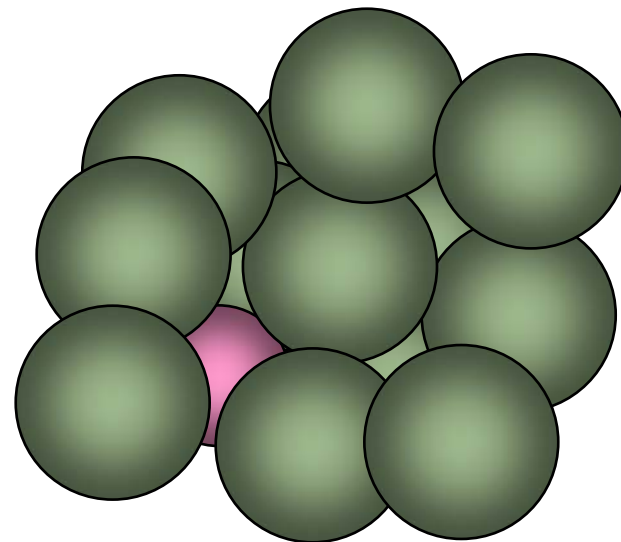



Traditional Science of Innovation

— Step 1: Generate ideas

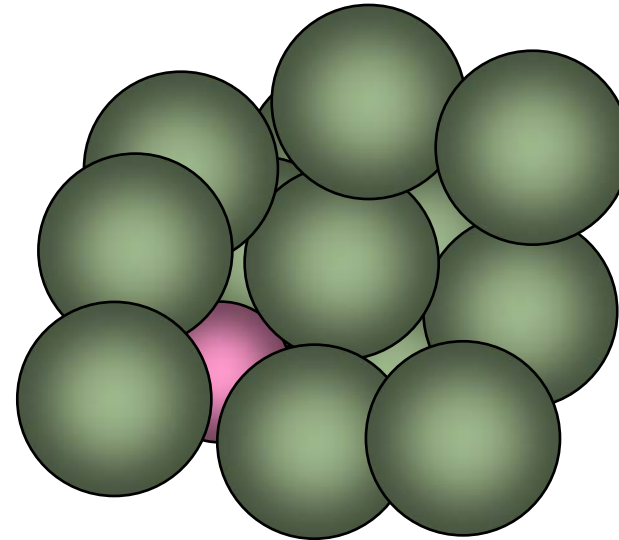

— Step 2: Filter ideas

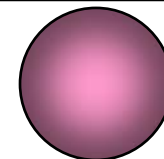
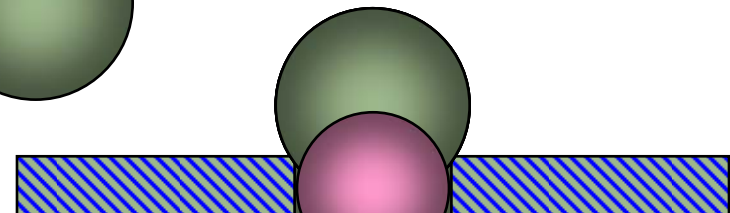
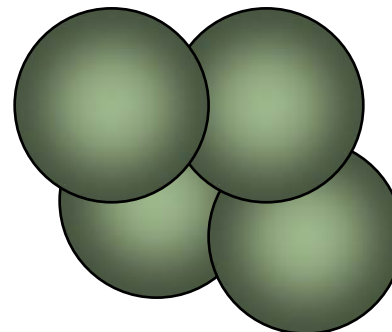



The Existing Innovation Process Is Inefficient

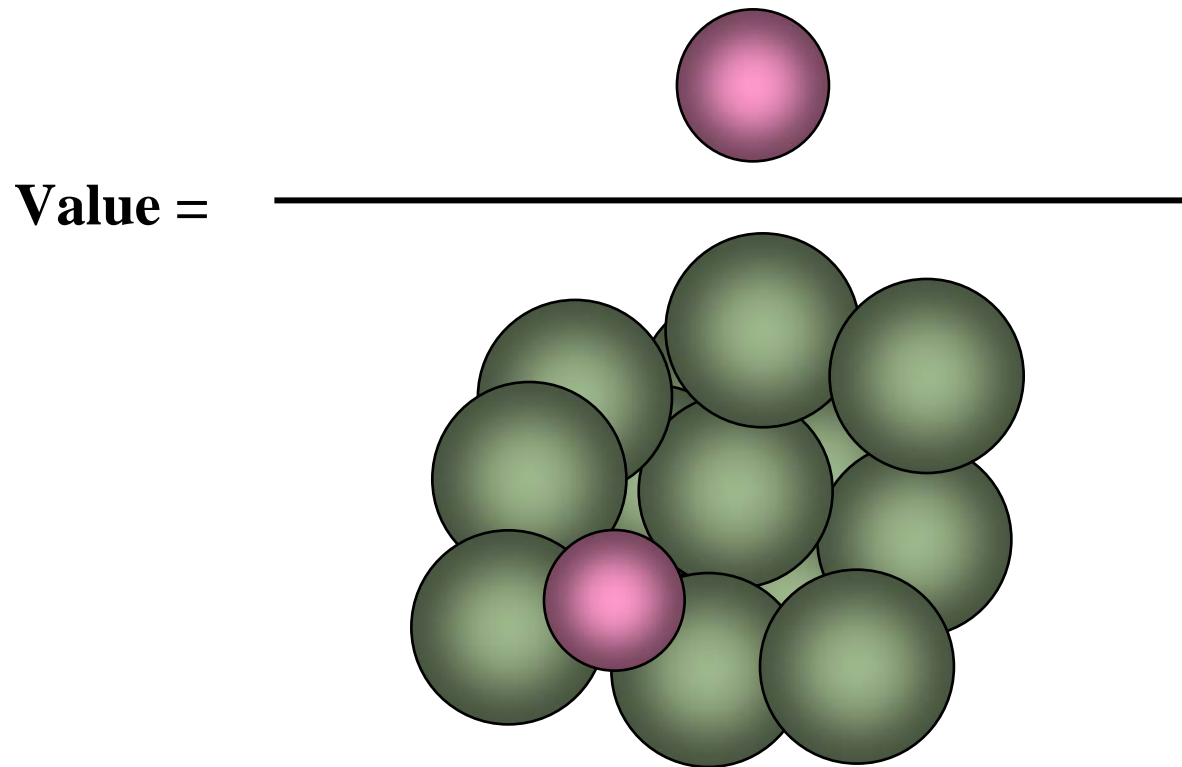



Ideal Efficiency

$$\text{Ideal Value} = \frac{\text{Ideal}}{\text{Ideal}} = 1$$



Innovation Killers

1. Project Constraints
2. Psychological Inertia
3. Limited Breadth of Knowledge and Information Overload
4. Giving up and/or compromising too easily
5. Not-Invented-Here Syndrome
6. Unable to Forecast the Future
7. Solving the Wrong Problem

Innovation Killers are everywhere

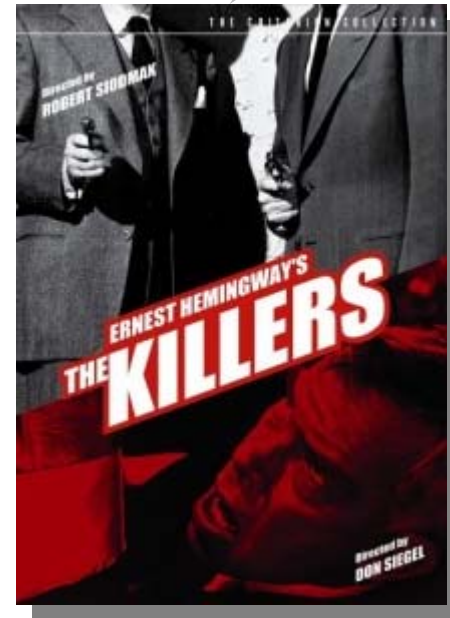



Human Limitations — Psychological Inertia

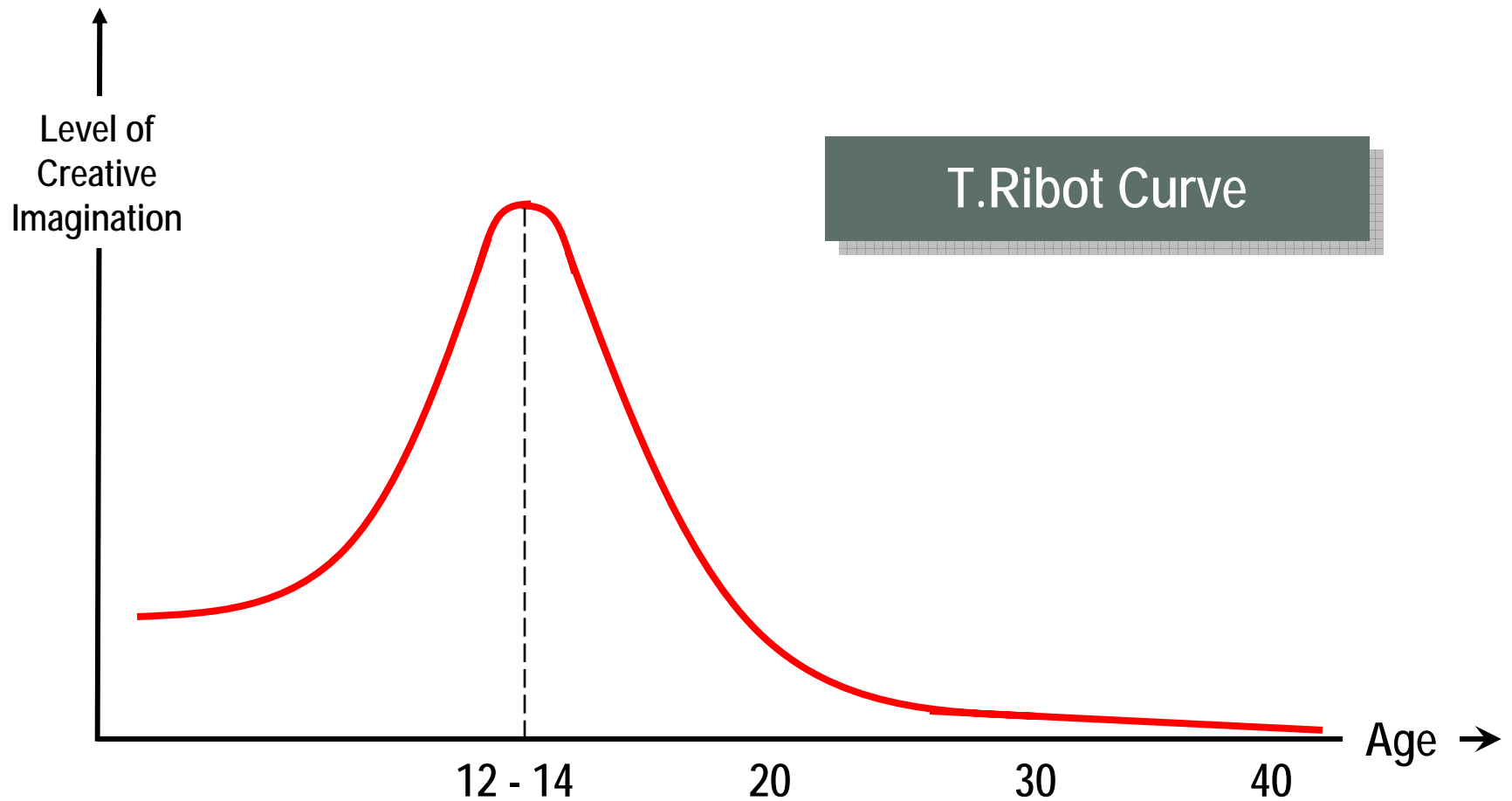



Psychological Inertia





Shifting the Innovation Paradigm

Innovation is significant movement along the Main Parameters of customer Value (MPV)

- Innovation can be an efficient, ***predictable*** process
- Structured analytical and problem-solving ***methods*** exist to achieve technology innovation goals
- There is a world of technology, invented in ***other industries***, waiting to be applied to our clients challenges



G. Altshuller, Inventor of TRIZ



- Revolutionary approach: to analyze a technology instead of a thinking process
- Revolutionary result: trends of engineering system evolution are discovered



Trend of Dynamization Increase.

Technologies evolve along predetermined evolutionary paths

Trend Definition:

During evolution the engineering systems and their components constantly enhance flexibility, dynamicity, and adaptability

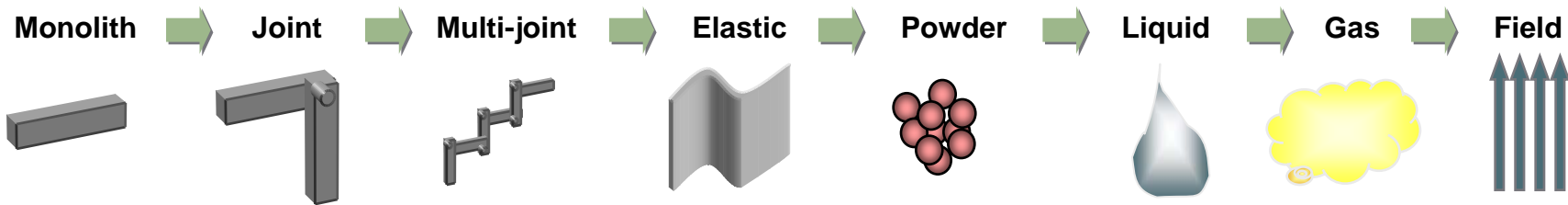

Example: Measuring distance

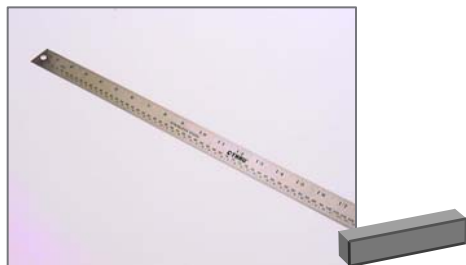

Monolith:
Ruler

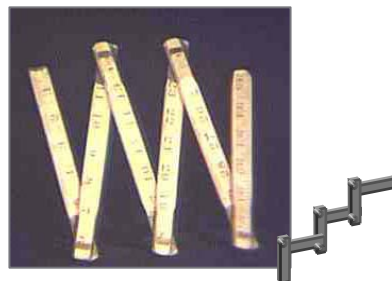

Multi-joint:
Folding Ruler

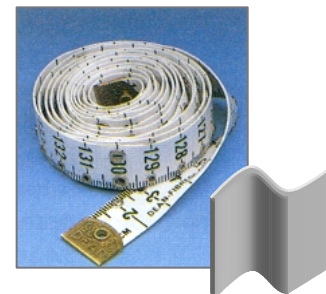

Elastic:
Tape Measure



Field:
Laser Measure



Trends of Evolution

Trend of Increasing Dynamicity

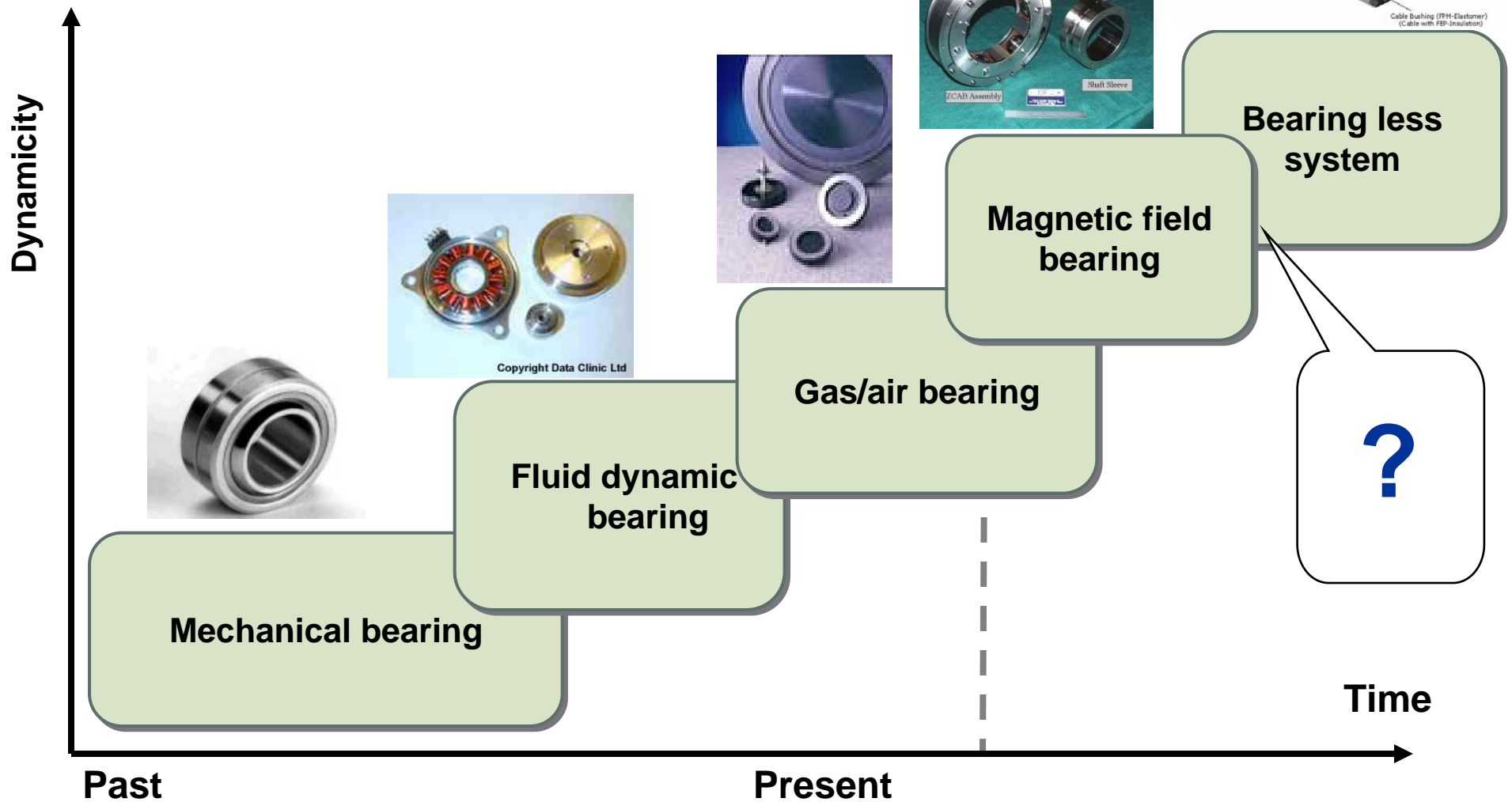



Trends of Evolution

Increasing of Controllability (example)

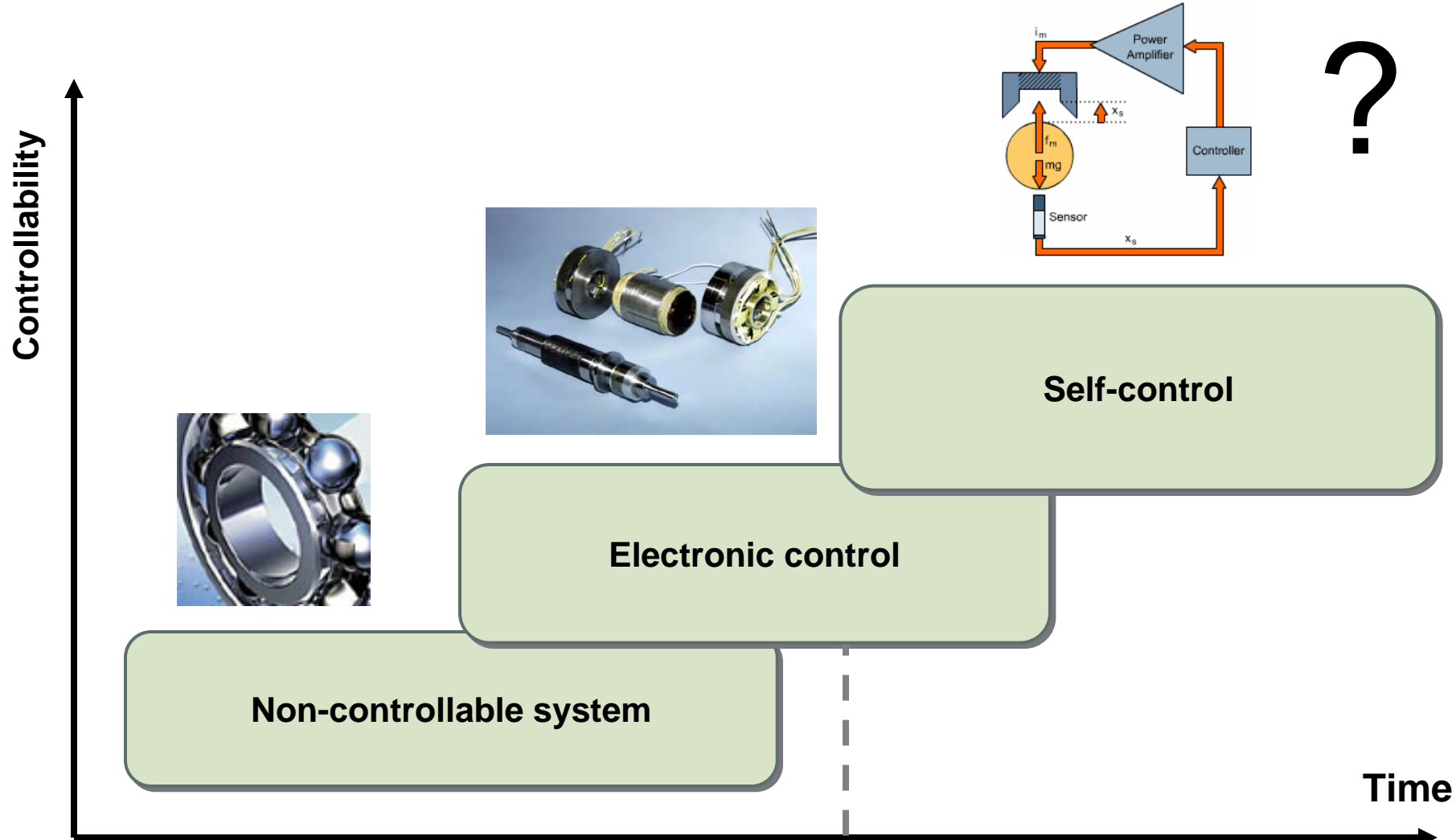



Trends of Engineering System Evolution

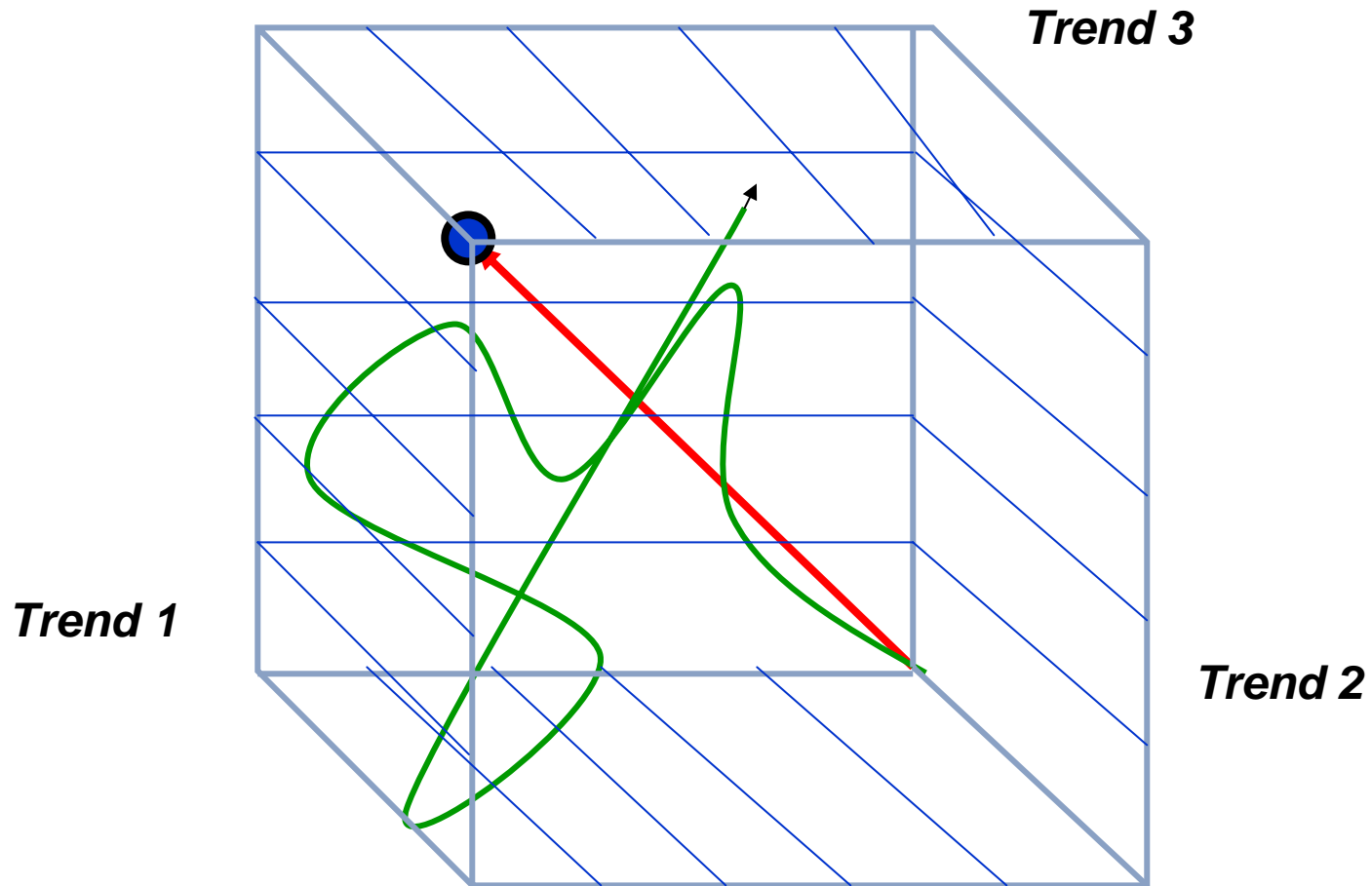



TRIZ Paradigm: Eliminate Categories of Unworkable Solutions So You Don't Have to Work to Find Them

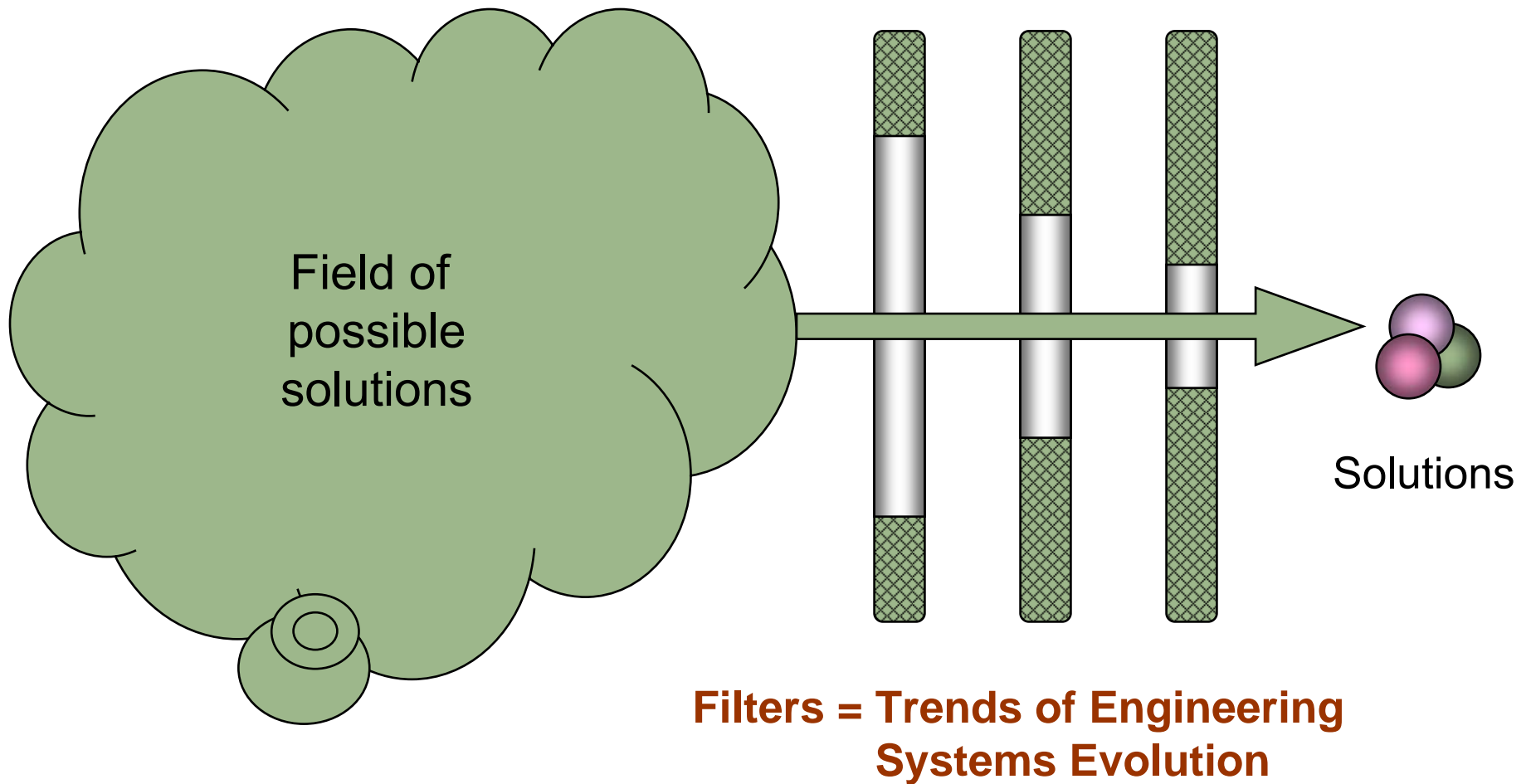



Exact Science of Innovation

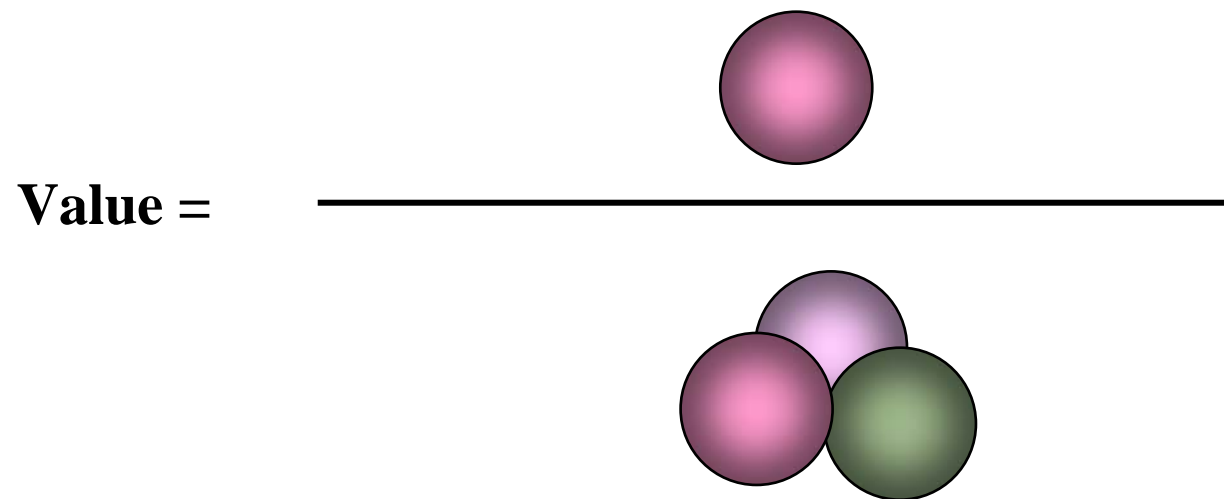



Cornerstones of G3:ID Product Innovation

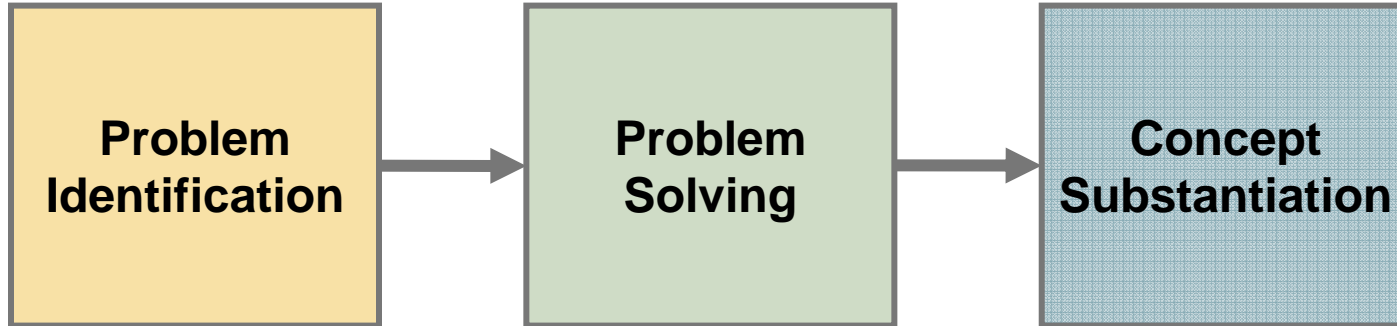



Liquid Soap for Kids. Dispenser.





GEN3's Approach to Innovation

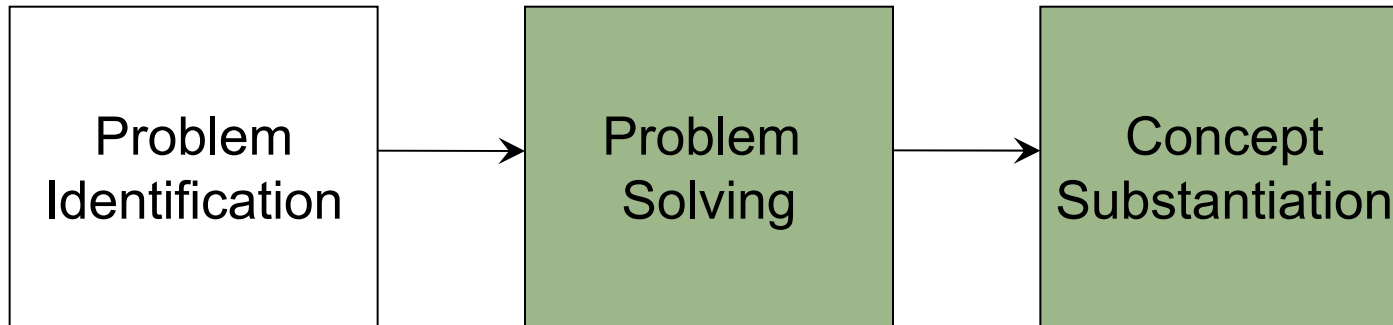

Methodology Steps	Issues Addressed
Functional Architecture of Existing Products Functional Diagnostics of Existing Products - Trimming New Functional Architecture Design New Functional Architecture Problems Identification	$V = F/C$ Solving the wrong problem The unidentified risk



Liquid Soap for Kids. Dispenser.

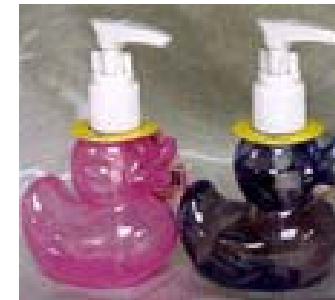
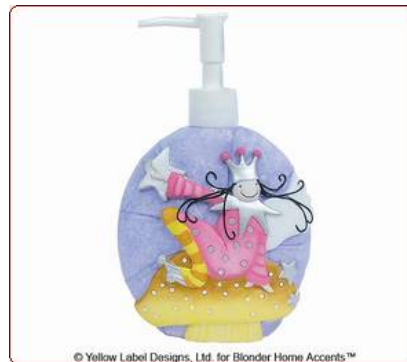



Soap Dispenser. Function Analysis.

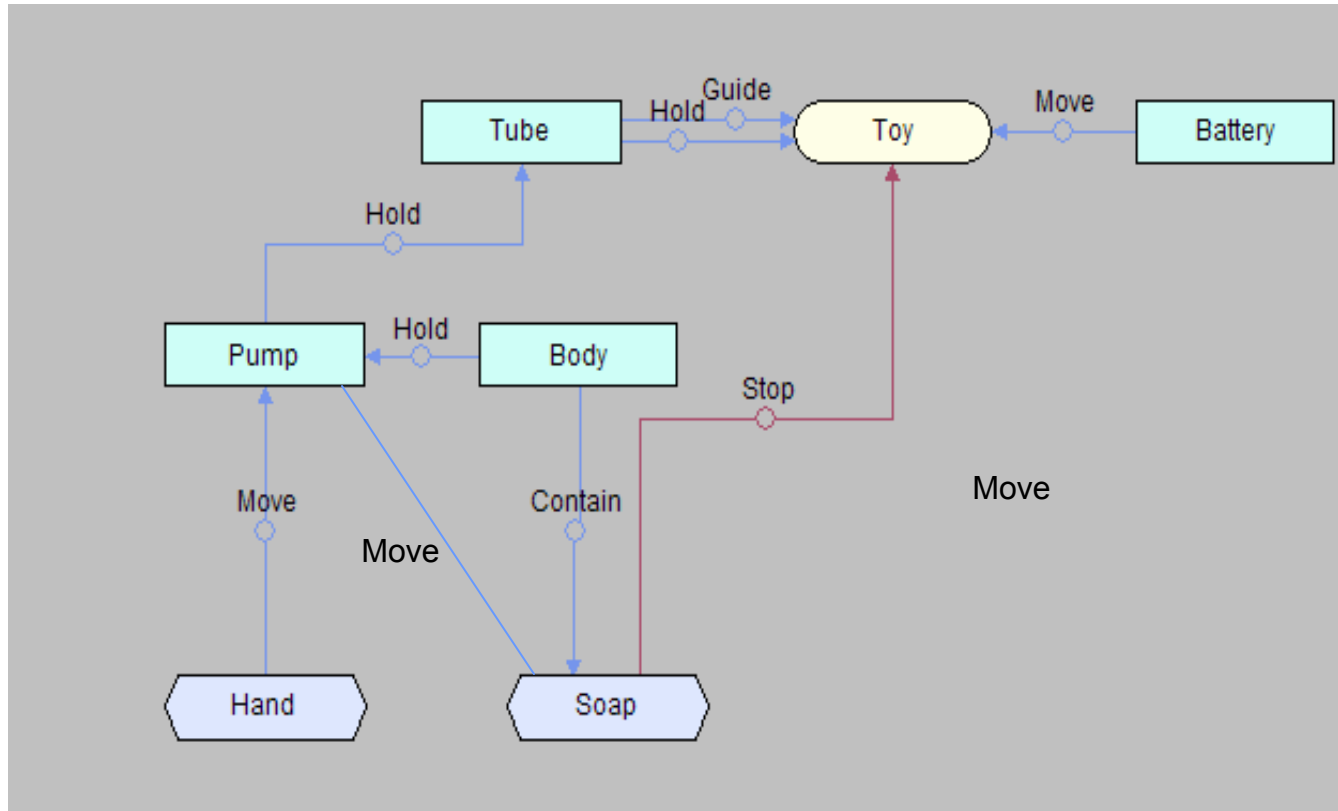



Value Analysis

Value Analysis guides the Innovation strategy

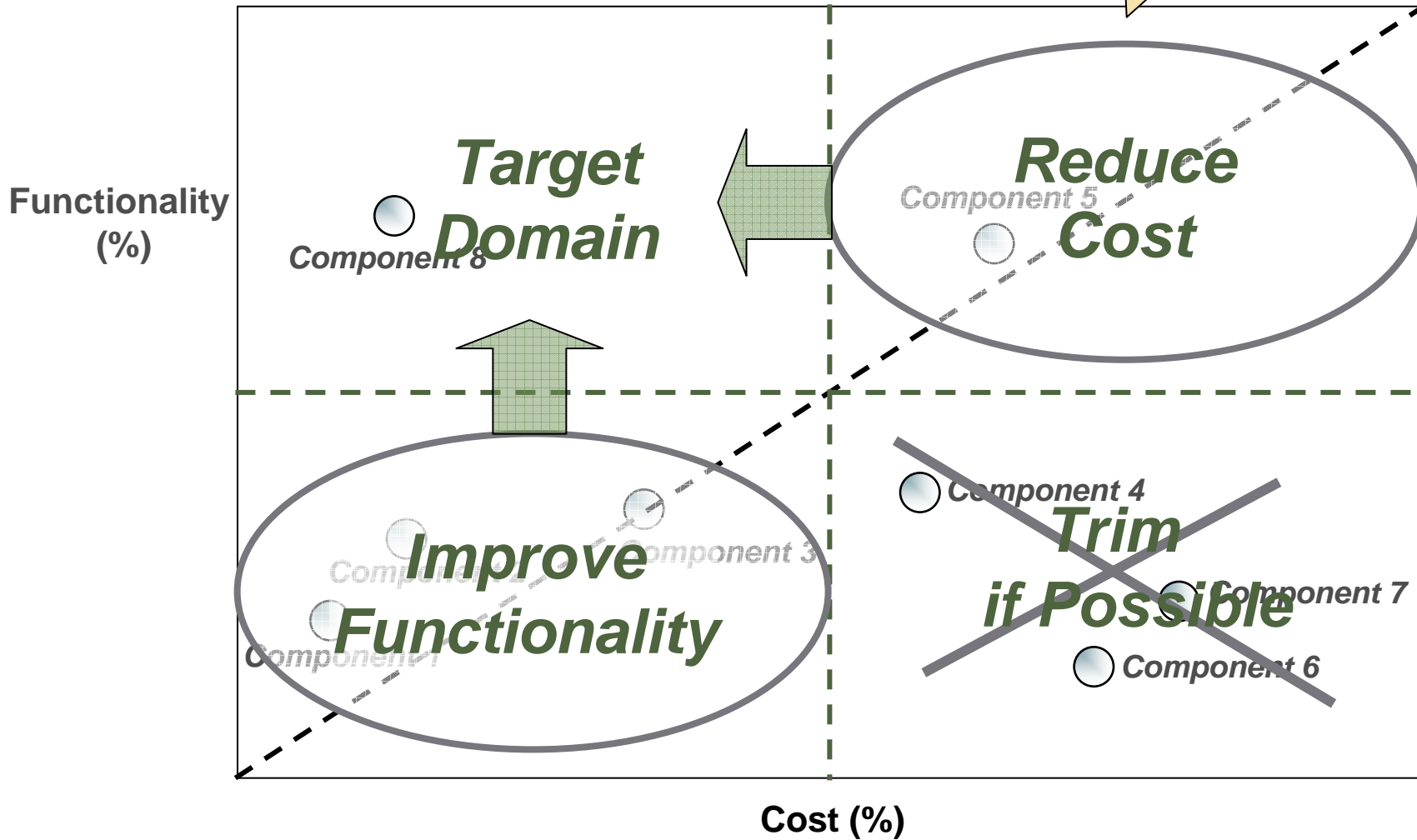



Trimming

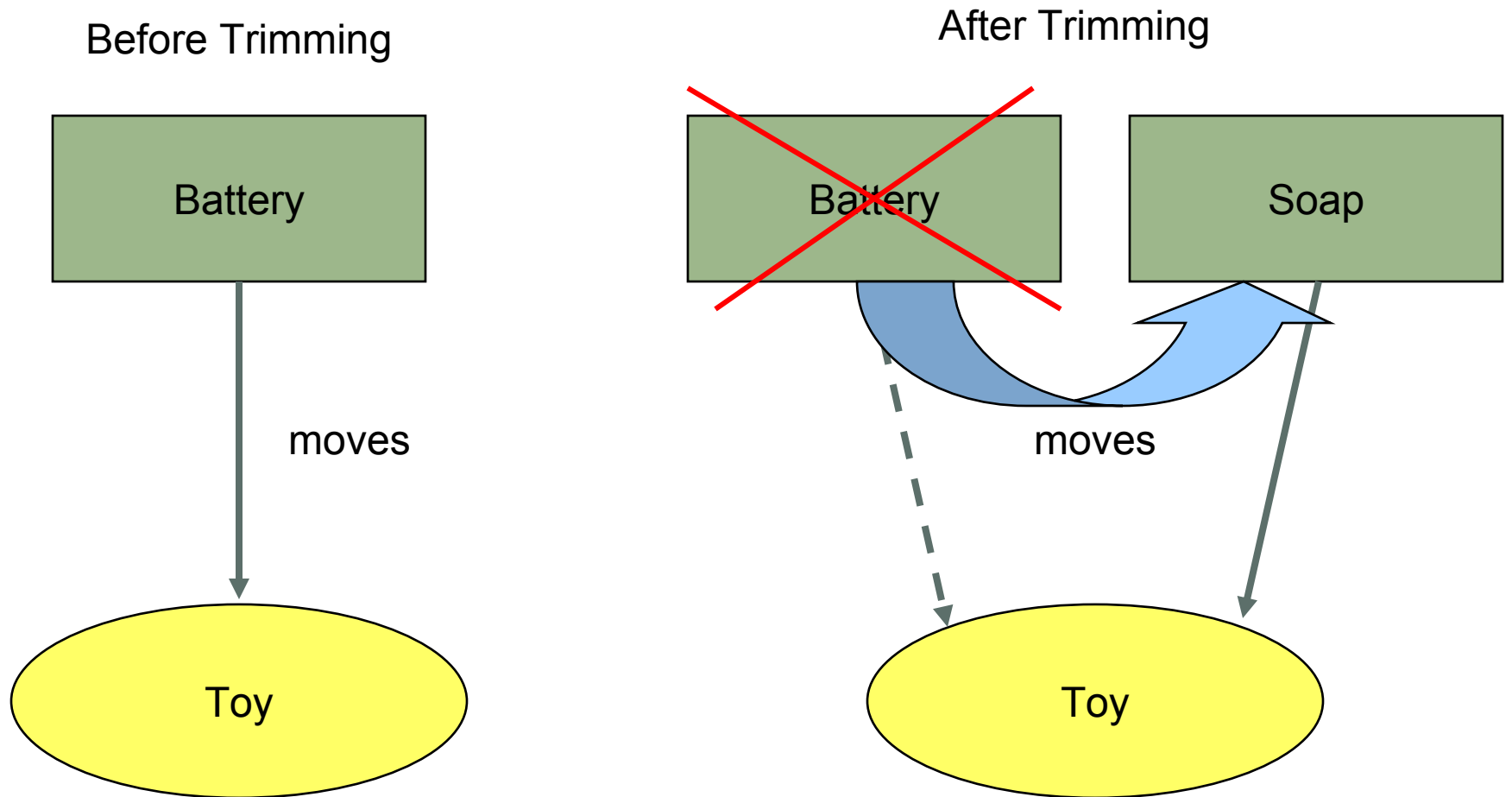



Soap Dispenser

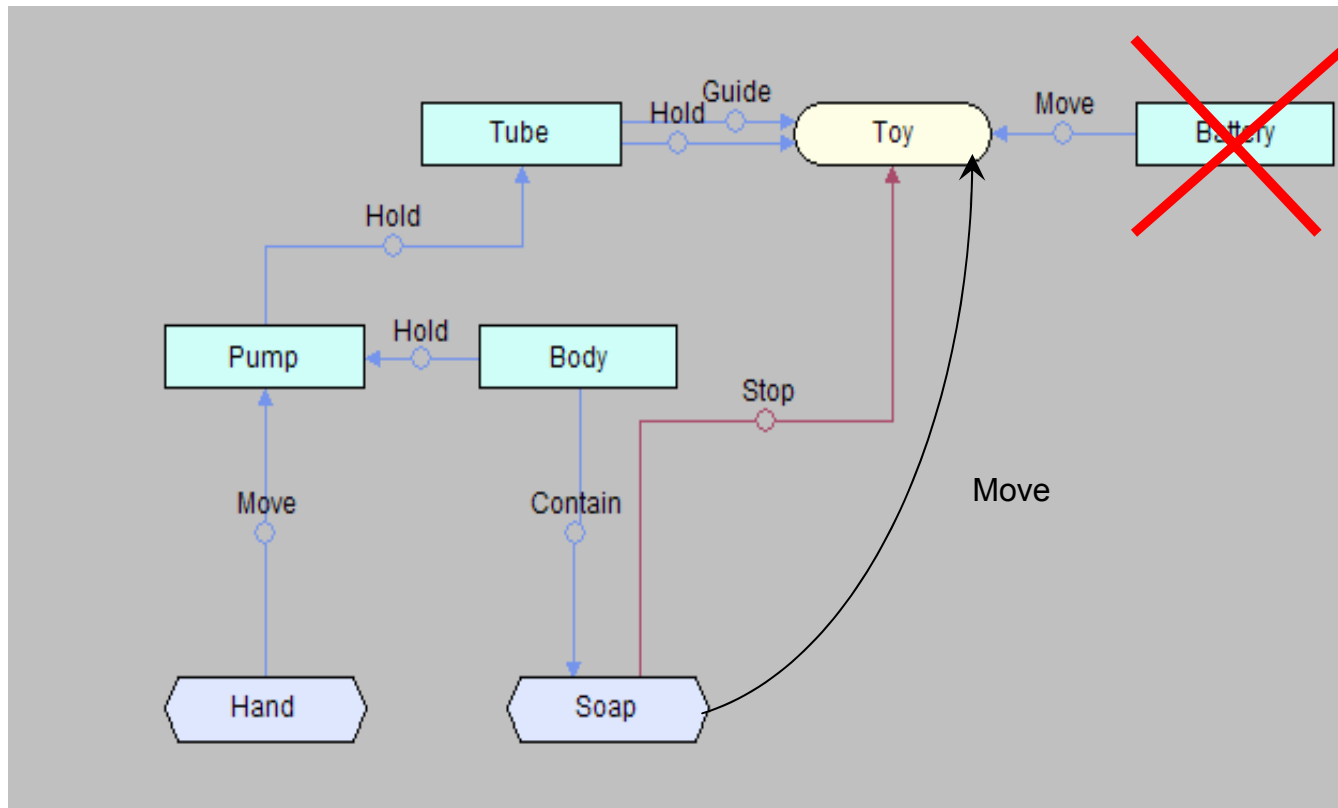



GEN3's Approach to Innovation

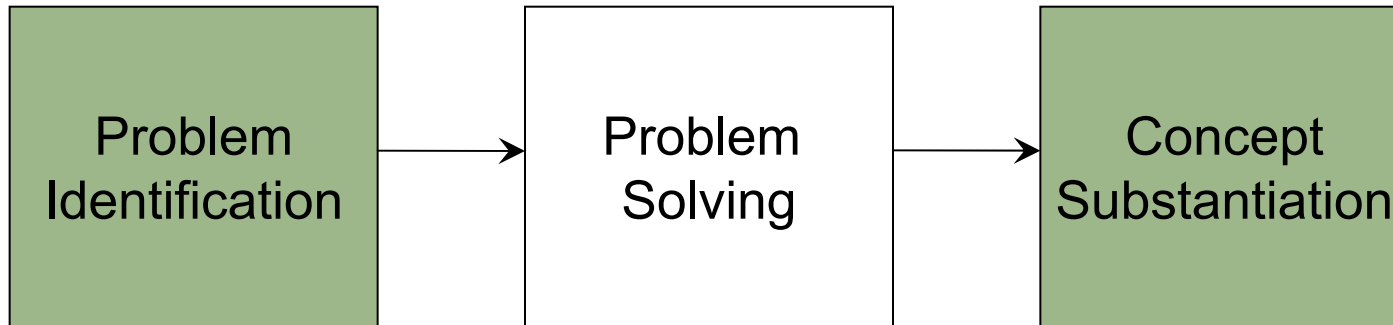

Methodology Steps	Issues Addressed
<p>Solving New Functional Architecture Problems</p> <ul style="list-style-type: none">-<i>Functional Taxonomies of Science and Technology</i>-<i>Function Oriented Search using Natural Language Processing</i>-<i>Trends of Technology Evolution</i>-<i>Inventive Principles</i>	<ul style="list-style-type: none">Human limitations – <i>Psychological inertia</i>Limited search for solutionsMissing a moving targetCompromise – <i>the sire of mediocrity</i>



Engineering Contradictions and Altshuller's Matrix

The goal of applying engineering contradictions and Altshuller's Matrix is to solve Key Problems

Parameter that gets degraded

Parameter you want to improve

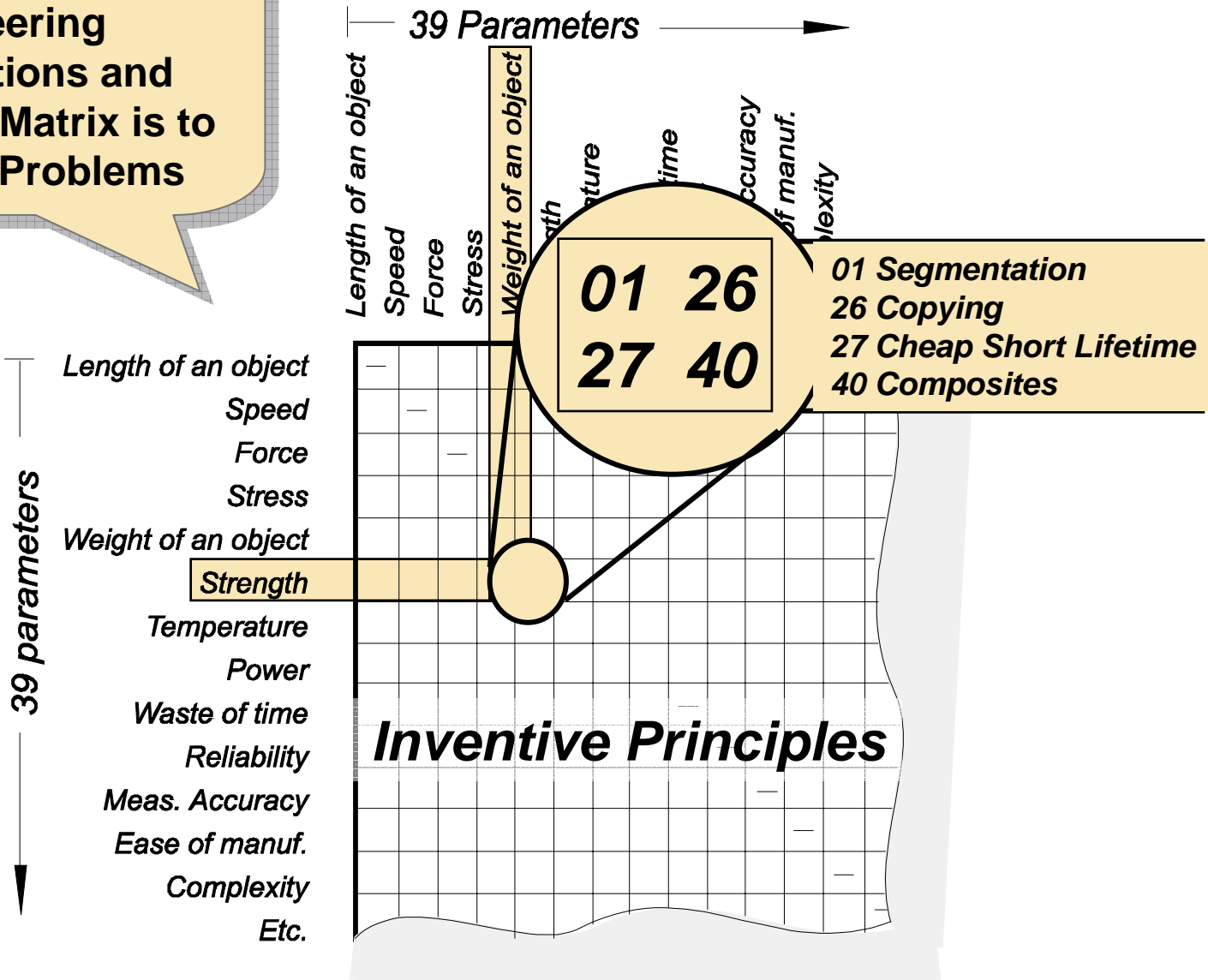



Soap Dispenser

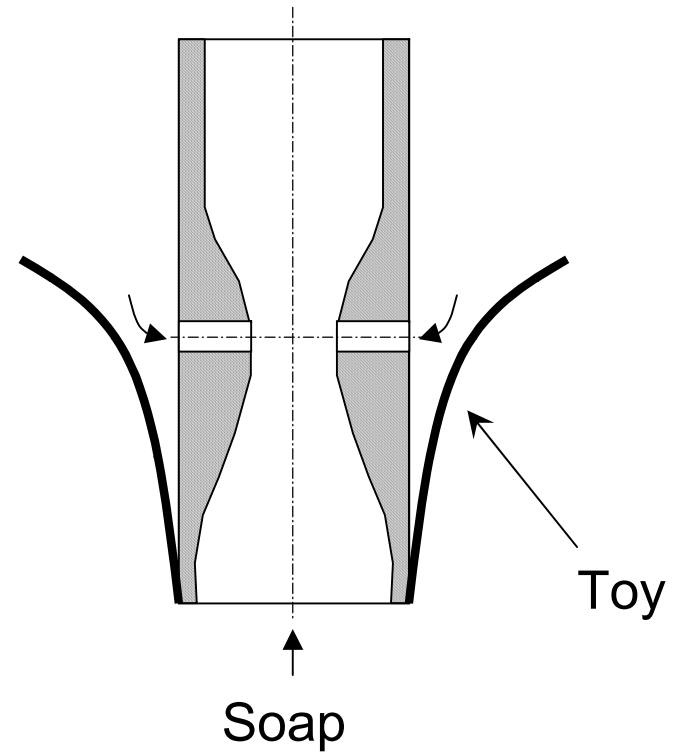
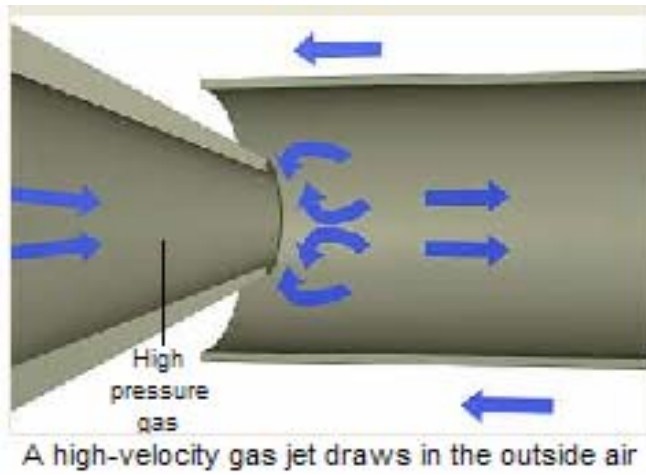



Trends of Engineering System Evolution



General Structure of the TESE

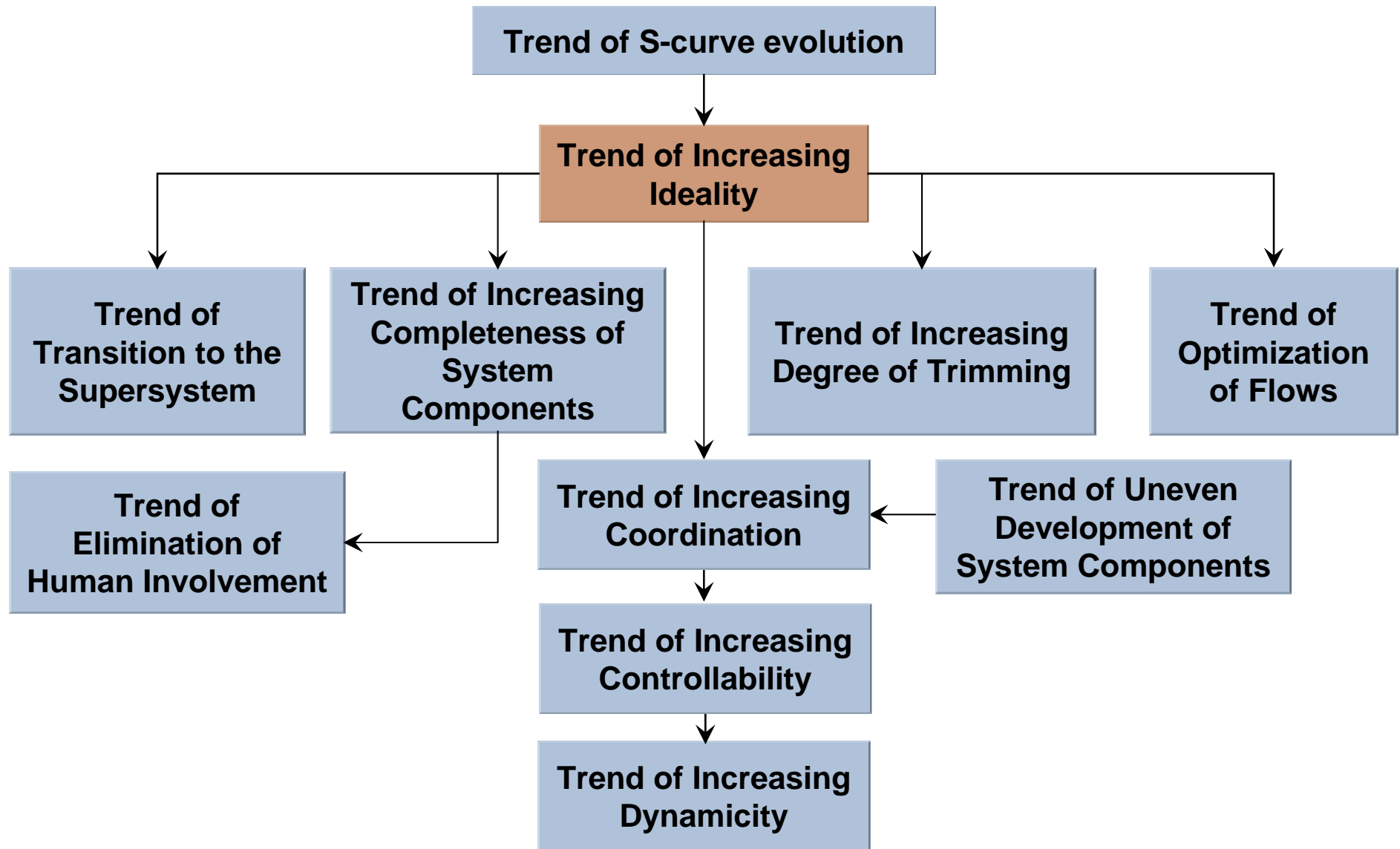



Trend of Transition to the Supersystem

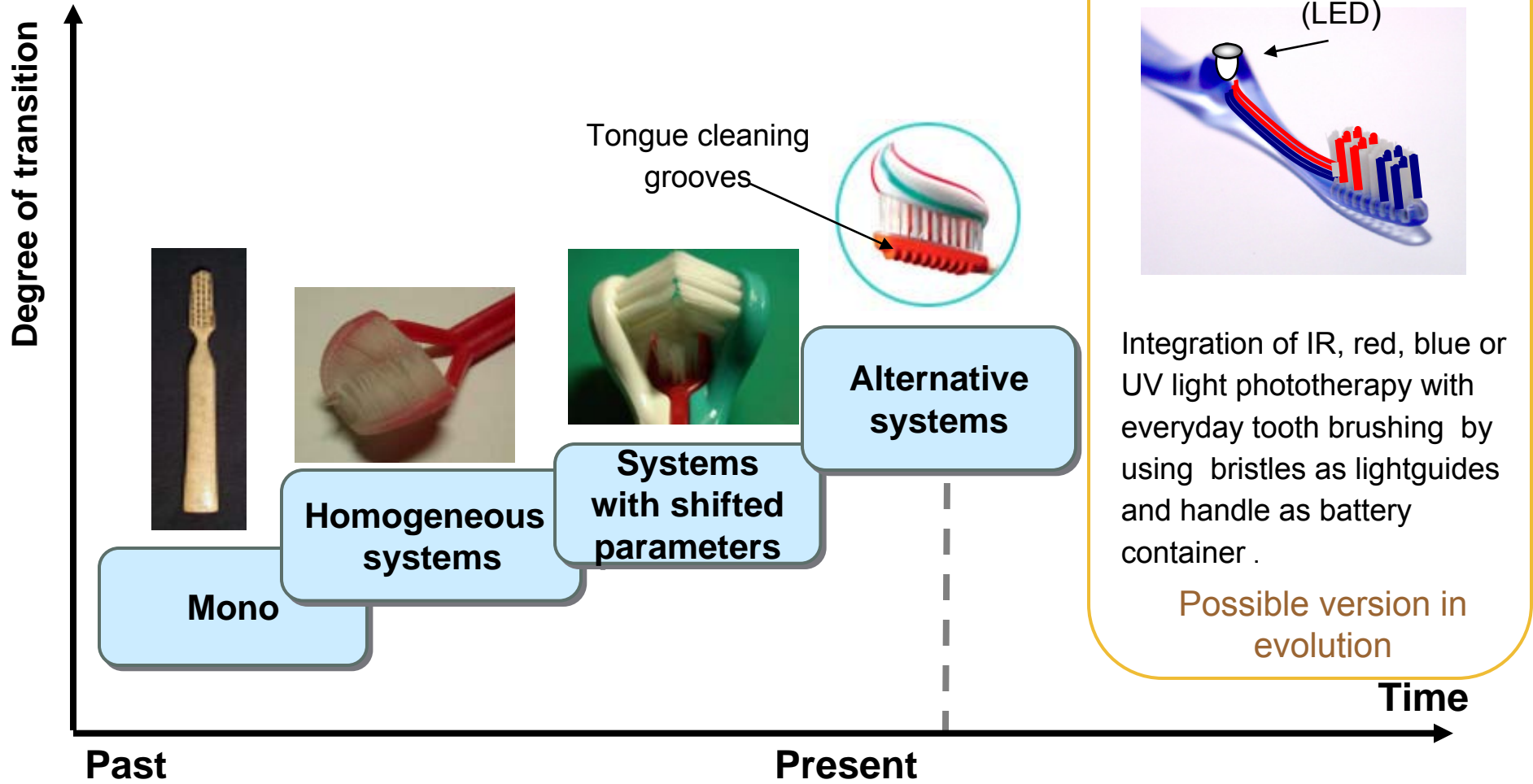

Changes in the toothbrushes will ultimately cause changes in toothpastes (broader supersystem)



Trend of Increasing Degree of Trimming

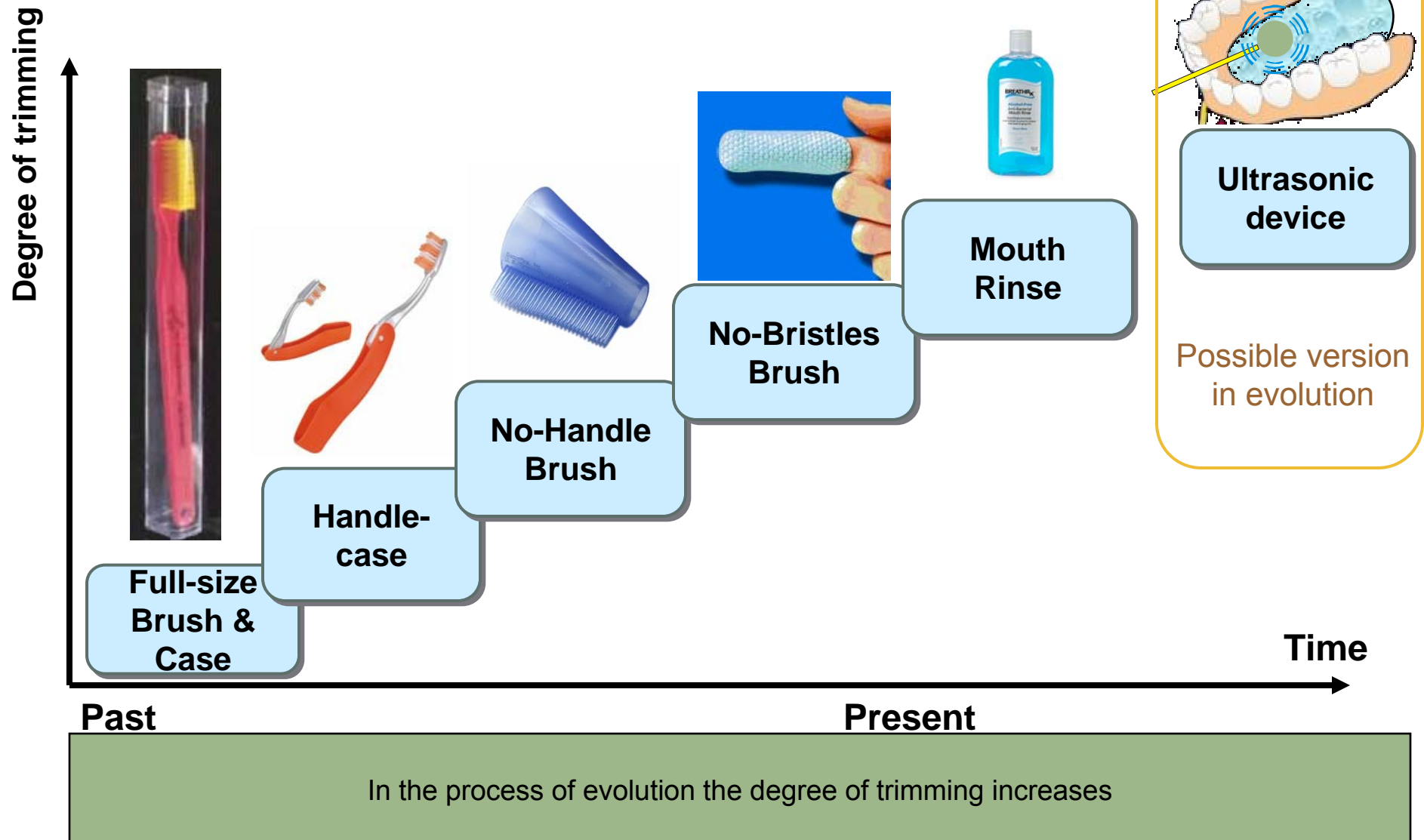



Trend of Increasing Controllability

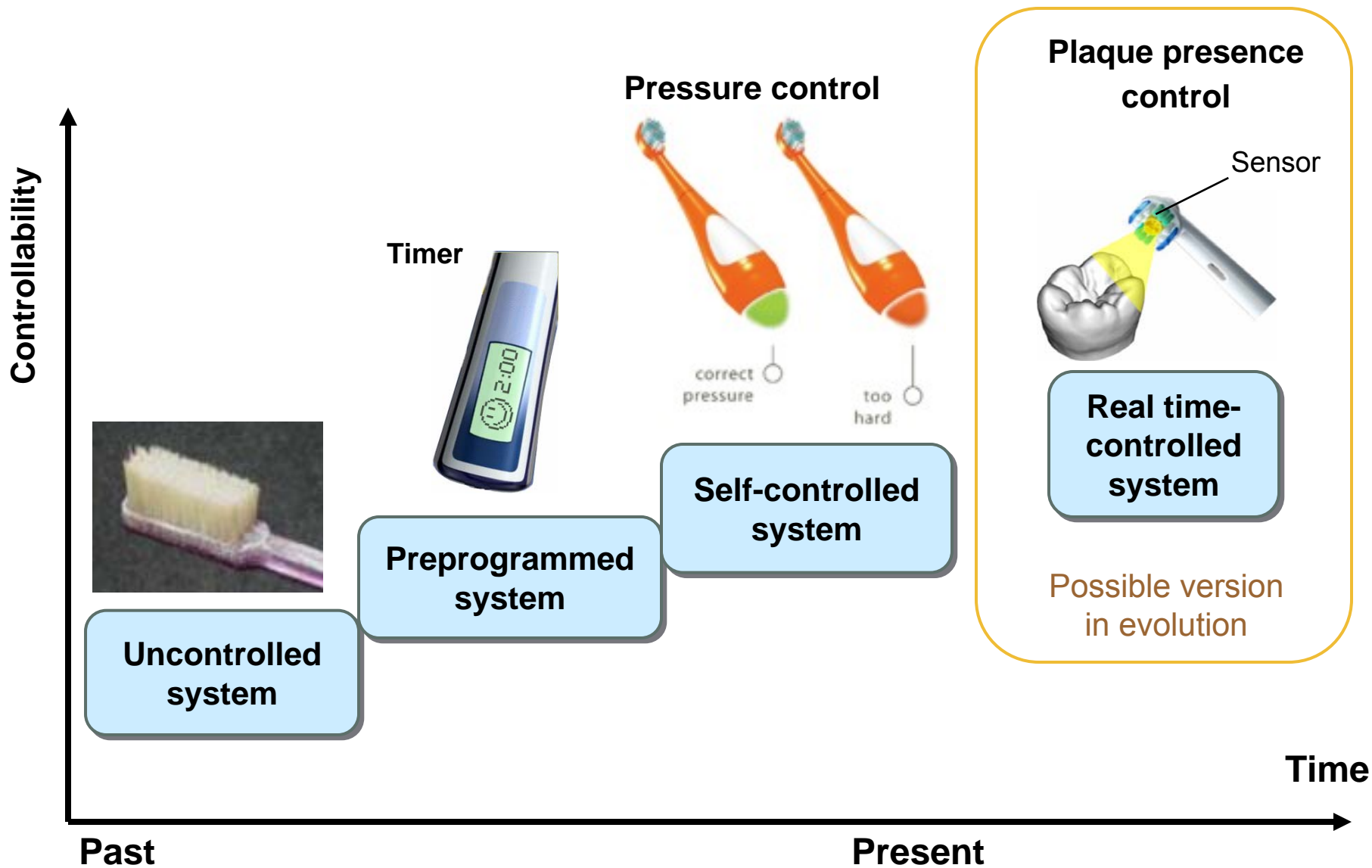



Trend of Dynamization Increase

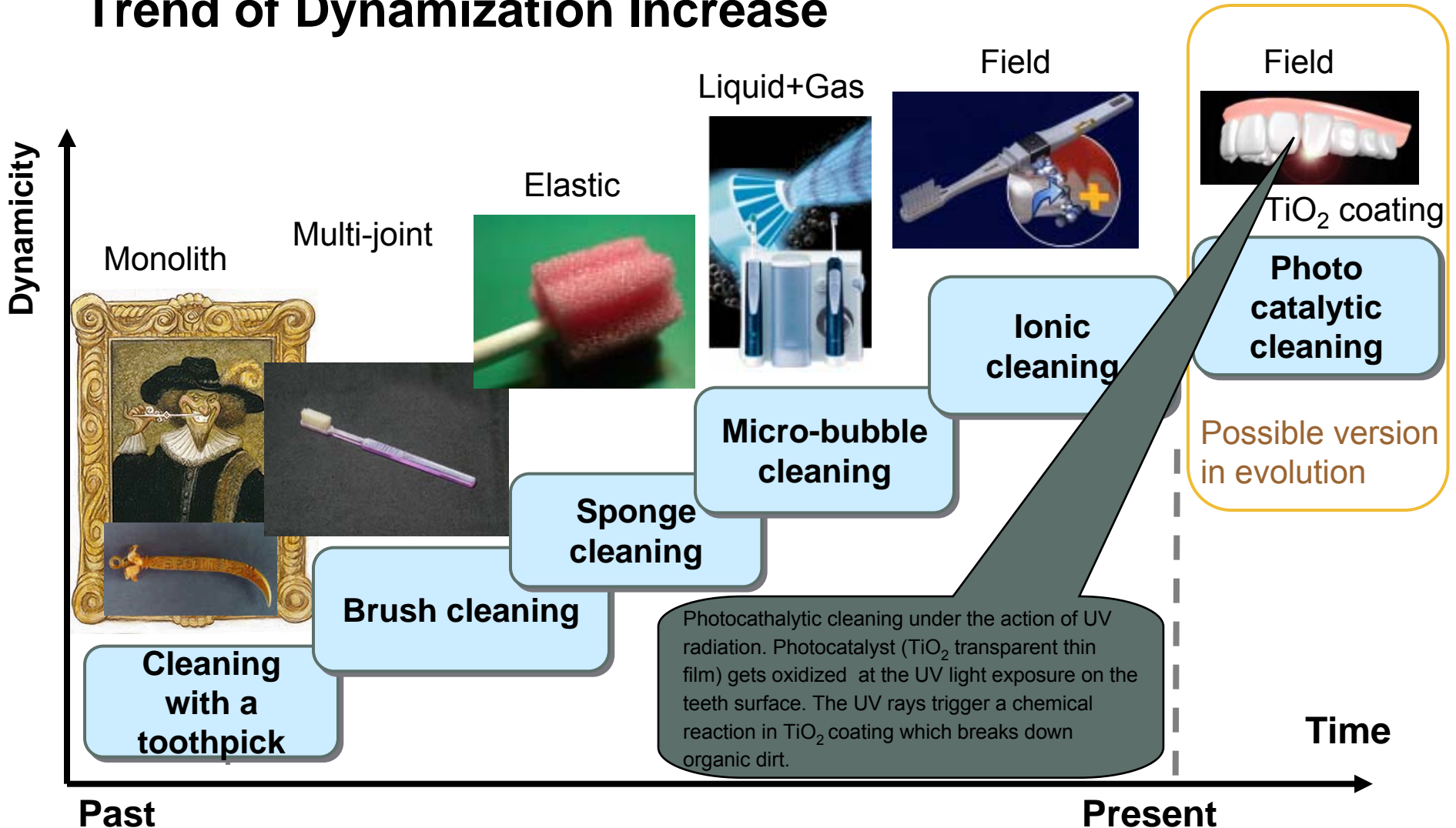

In the process of evolution the toothbrush working tool evolves from solid to field

Trend of Dynamization Increase. The Handle.

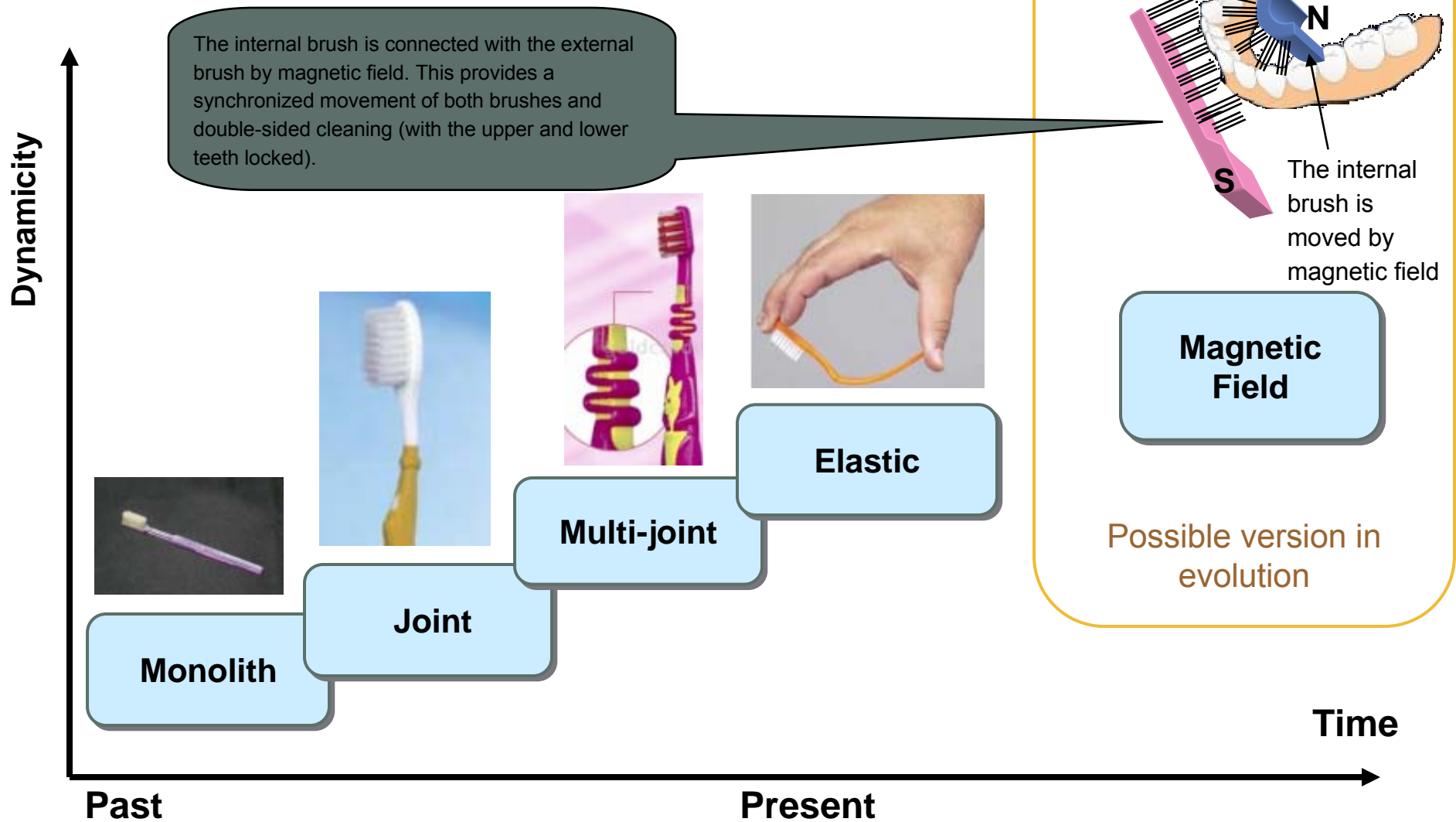



Trend of Dynamization Increase. The Head.

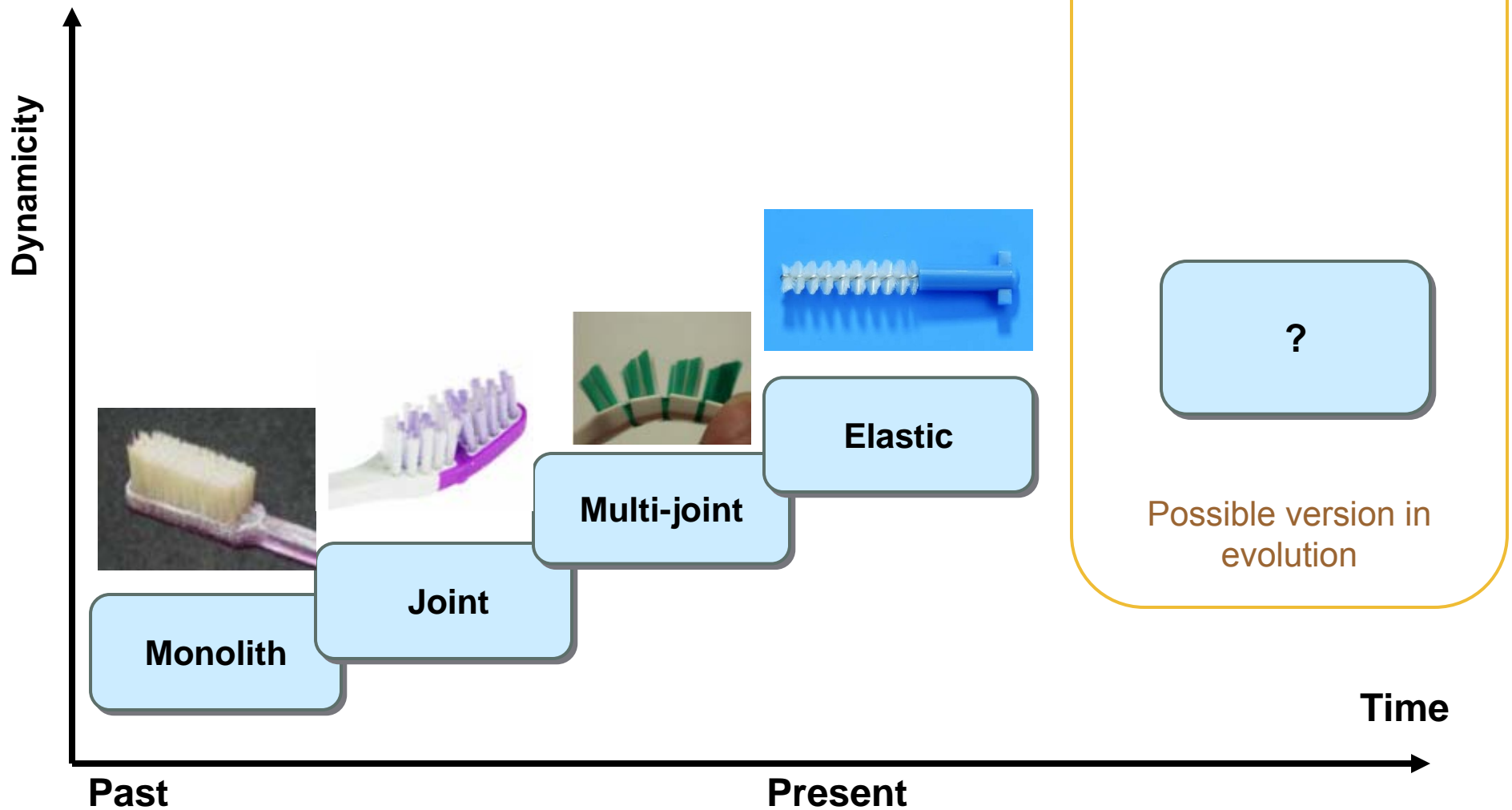



S-Curve Law of Evolution

Main parameters

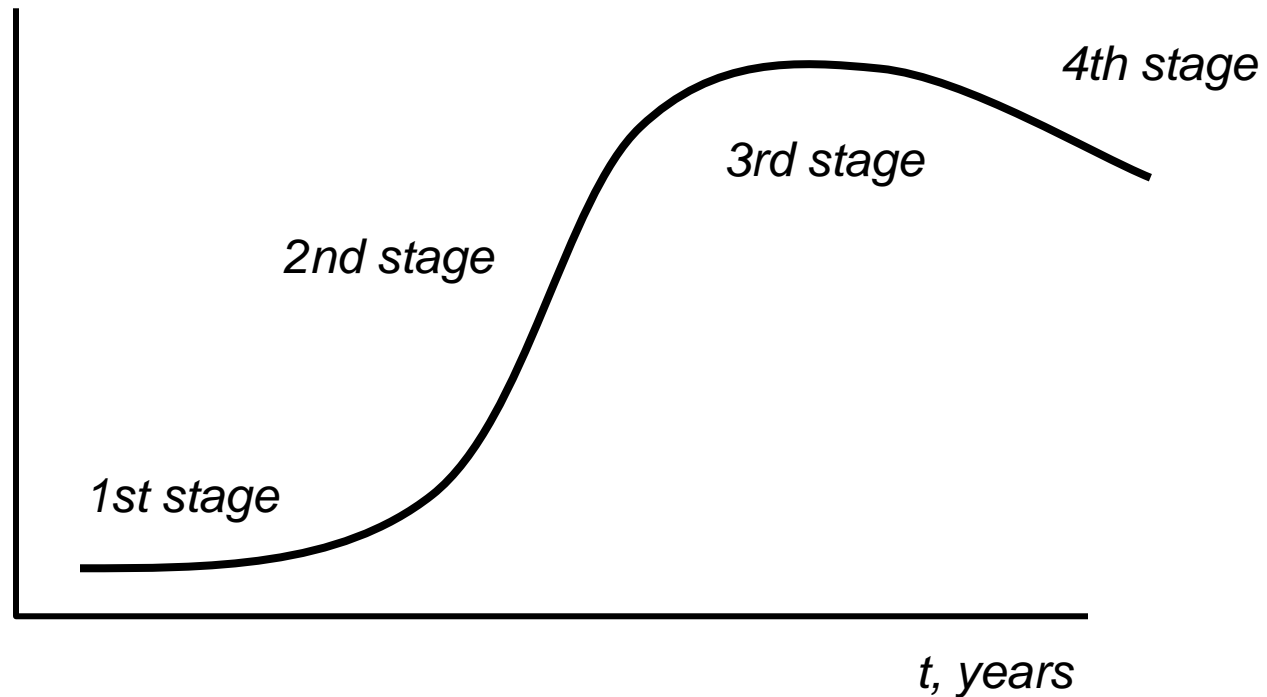

All engineering systems evolve along their S-Curves and pass through 4 typical stages



S-Curve Analysis and MPVs (Main Parameters of Value)

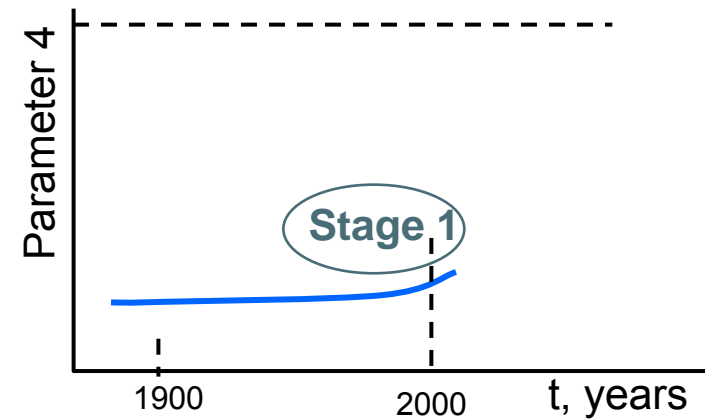
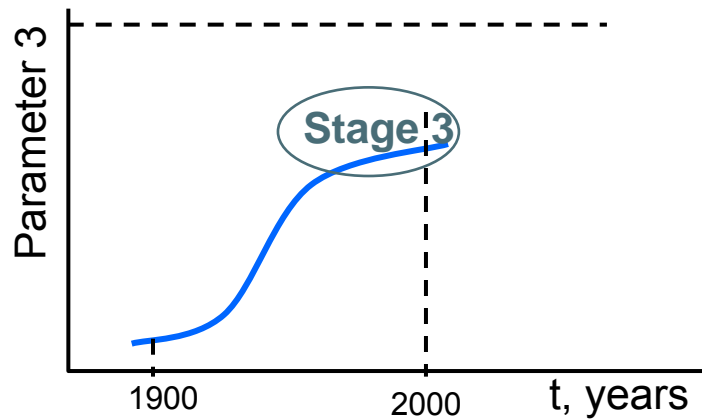
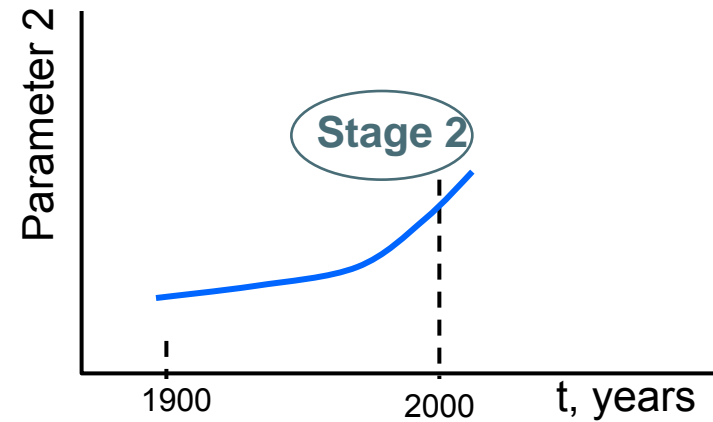
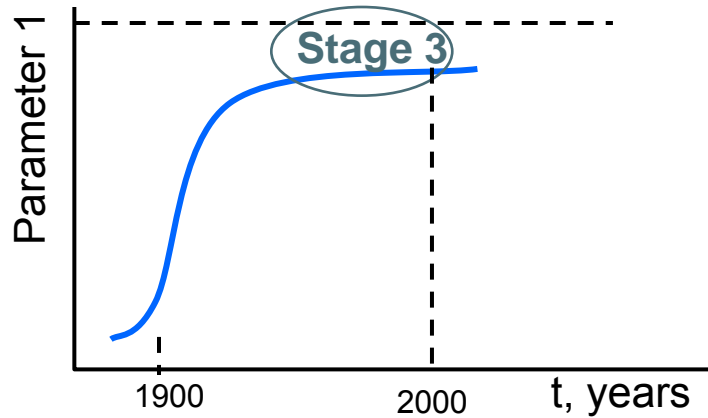



G3:ID for Patent Strategies



G3:ID for Patent Strategies

S.N	Type of Patent Strategy	Tools
1.	The Antidote Strategy	Function Analysis, Cause Effect Chains Analysis, Trimming, Function Oriented Search
2.	The Picket Fence Strategy	S Curve Analysis, Trends of Evolution, Function Oriented Search, Reverse Contradiction Analysis
3.	The Tall Gate Strategy	S Curve Analysis, Trends of Evolution, MPV Analysis
4.	The Submarine Strategy (old and new)	Trends of Evolution, Function Oriented Search
5.	The Counter Attack Strategy	Function Oriented Search, Reverse Contradiction Analysis, Semantic Tools
6.	The Stealth Counter Attack Strategy	Function Oriented Search, Reverse Contradiction Analysis, Semantic Tools
7.	The Competitive Patent Circumvention Strategy	Function Analysis, Cause Effect Chains Analysis, Trimming
8.	The Patent Circumvention Strategy (Doctrine of Equivalents and Prosecution History - Estoppel)	Function Analysis, Function Oriented Search
9.	The Blanketing Strategy	Function Oriented Search, Trends of Evolution
10.	The Bargaining Chip Strategy	Trends of Evolution
11.	The Cut-Your-Exposure Strategy	Function Oriented Search



Competitive Patent Circumvention: Example

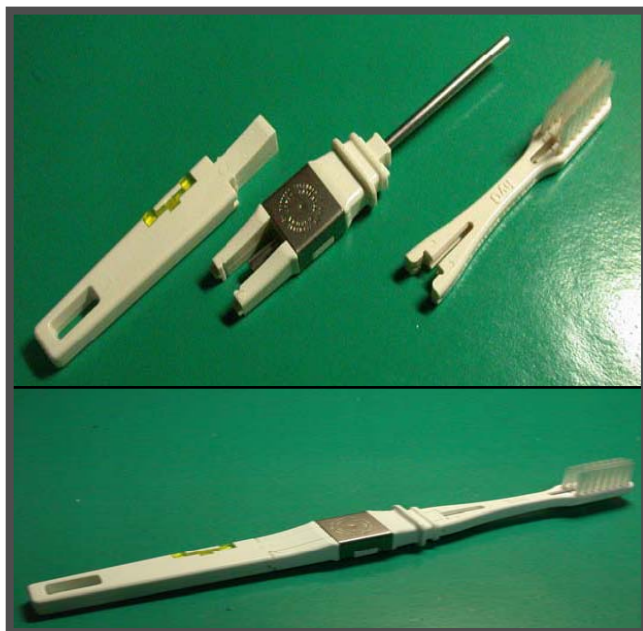

- Scenario: Ionic Toothbrush
 - The Independent claim of a patent describes a toothbrush that consists of a head containing bristles, and a handle that holds the head.
 - The handle and head also hold an electrode that is powered by a battery inside the handle
 - The electrode ionizes air for easy plaque removal



Ionic Toothbrush: Function Model and Trimming

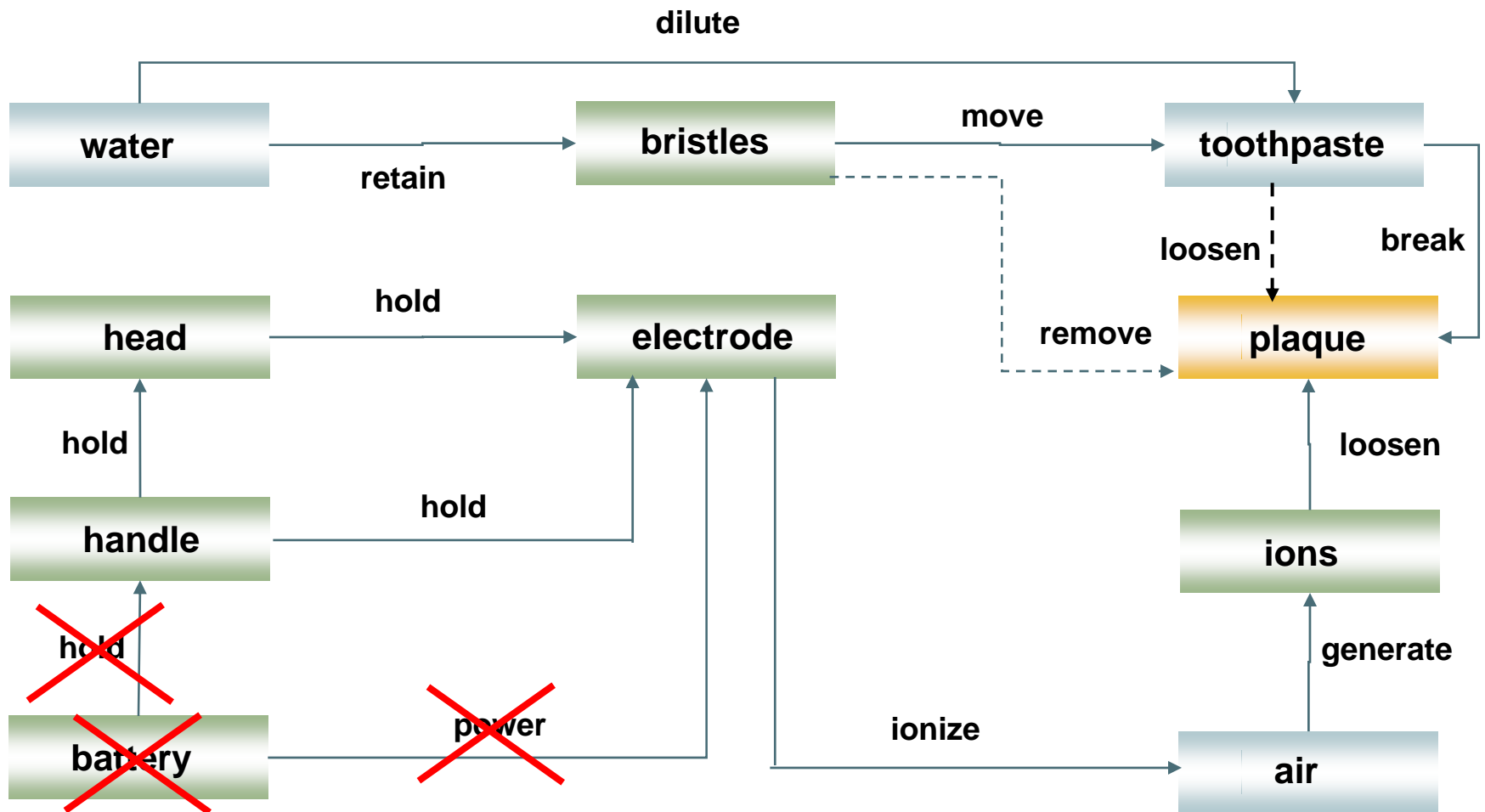



Ionic Toothbrush: Function Model and Trimming

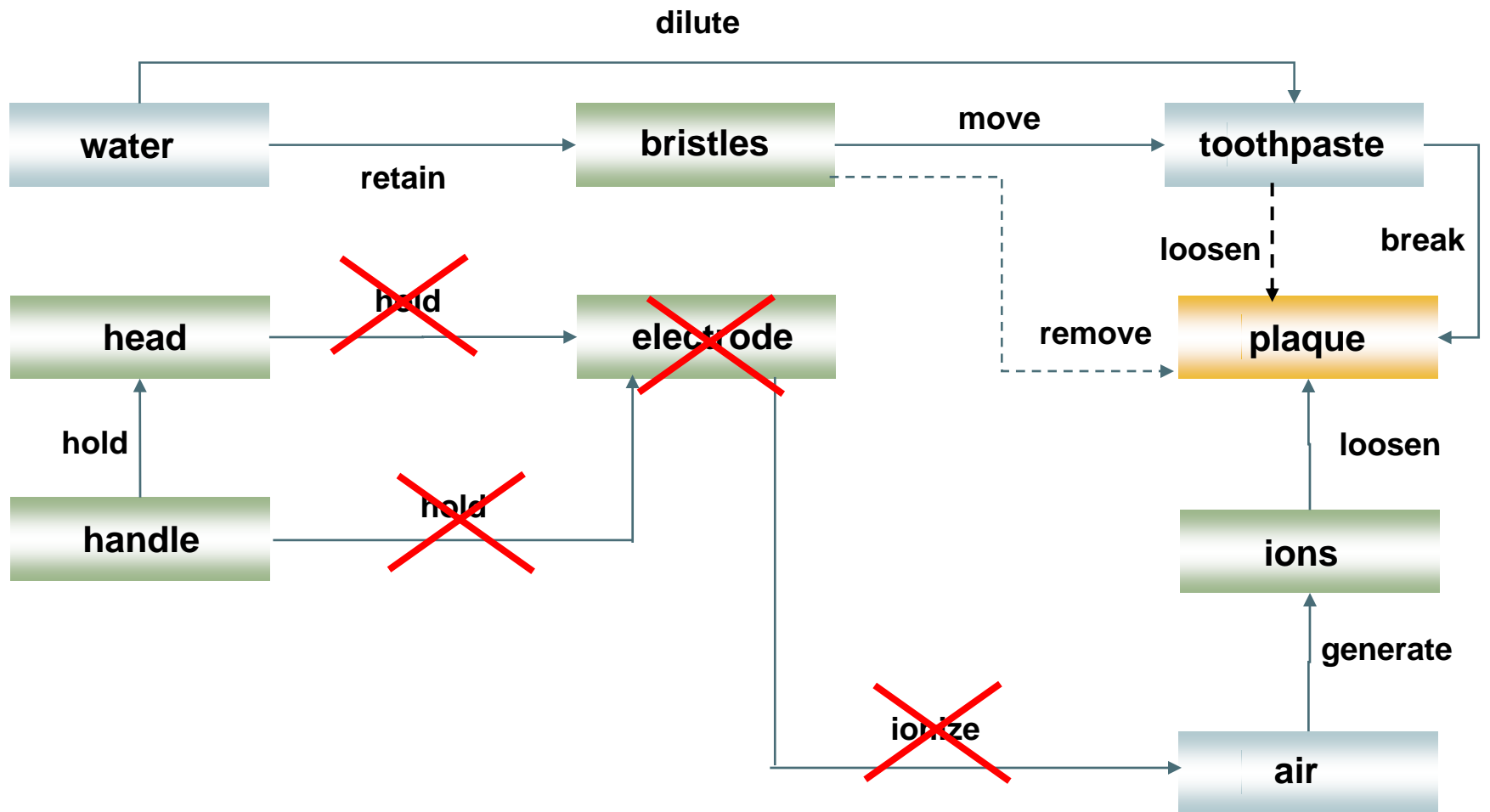



Ionic Toothbrush: Function Model and Trimming

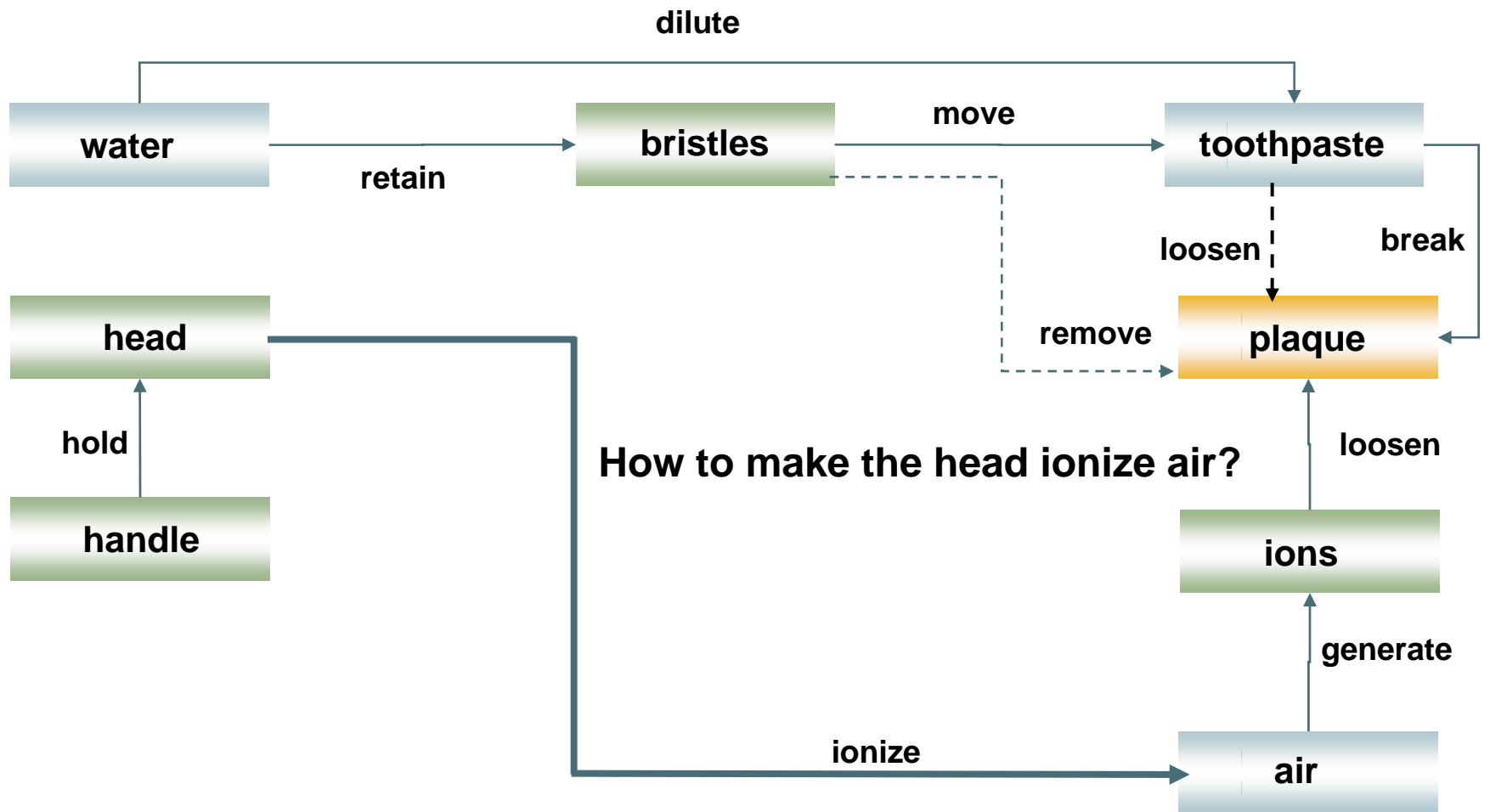



Ionic Toothbrush: Solution



- Solution
 - The toothbrush head surface is covered with an alloy that, when in contact with toothpaste and water, works as an active couple and generates voltage.
 - As a result the head itself ionizes the air near the plaque

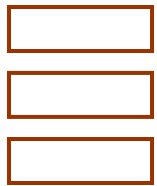

G3:ID – Innovation Discipline Approach